



Industrial - Industriel

Sanding Products - Produits de ponçage

Abrasifs JJS inc.

Founded for more than 30 years ago, Abrasifs JJS Inc. is an exclusive Canadian importer of coated abrasives made in Switzerland by sia Abrasives.

An experience team:

- Abrasifs JJS employs over 45 experienced and dedicated employees.

Two facilities in Canada for a better service:

- 40000sq. feet (3700sq.m) warehouse and conversion centre at Lévis Quebec, with over 5 million dollars inventory
- Sales and Marketing organisation in Ontario
- 11 Technical Specialists on the road across Canada
- 24 hour personalized service
- Technical service and training available
- Full line of abrasive products for wood, metals, composites, panels, and body shops

sia Abrasives –

Your key to a perfect surface!

We are a Swiss company (a Bosch company since 2008) with more than 130 years of abrasives knowledge.

sia Abrasives, with its headquarters in Frauenfeld, Switzerland, is one of the world's leading suppliers of innovative abrasives. The company develops, manufactures and markets complete abrasive systems, tailored to specific requirements and applications, for the surface treatment of every types of surface. sia Abrasives employs around 1310 people worldwide and is represented with partners in over 80 countries.

Technology leader

Our choice of premium materials, the latest production and manufacturing equipment and sophisticated production technologies enable us to provide sanding products at the highest level in constant quality.

Innovative solutions

In close collaboration with the leading varnish and paint manufacturers of the furniture and automotive industries, new abrasive standards are set by their own research and development trials. Trendsetting abrasives and genuine product innovations with trendsetting processes result in sanding surface technology.



JJS warehouse: 5 million dollars inventory
(Lévis, Québec) Inventaire de 5 millions dollars

Abrasifs JJS inc.

Fondé depuis plus de 30 ans déjà, les Abrasifs JJS Inc. est le dépositaire exclusif de produits abrasifs fabriqués en Suisse par sia Abrasives au Canada.

Une équipe expérimentée:

- Abrasifs JJS emploie plus de 45 personnes expérimentées et dédiées.

Deux points de service pour assurer un meilleur service:

- Centre de conversion et entrepôt de 3700 m. carrés (40000 pieds carrés)
à Lévis, avec un inventaire de plus de 5 millions de dollars
- Présence d'une organisation de ventes et marketing en Ontario
- Une équipe de 11 représentants techniques sur la route répartie à travers le Canada
- Un service personnalisé 24 heures
- Un service technique de haut niveau et possibilité de formation
- Ligne complète de produits abrasifs pour le bois, les métaux, les composites, les panneaux et la carrosserie

sia Abrasives –

votre solution pour une surface parfaite!

Nous sommes une compagnie Suisse (une compagnie Bosch depuis 2008) ayant plus de 130 ans de connaissance dans les abrasifs.

sia Abrasives, situé à Frauenfeld en Suisse, est un des plus important fournisseur mondial de systèmes de ponçage innovateurs. Il développe, fabrique et commercialise des systèmes complets de ponçage pour le traitement de tous les types de pièces et selon des exigences et des applications spécifiques du client. Le groupe sia Abrasives compte quelque 1310 employés dans le monde entier et se trouve représenté par de nombreux partenaires, dans plus de 80 pays.

Produits suisses de qualité

La sélection soignée de matières premières de haute qualité, les installations de fabrication et de confection les plus modernes et les technologies de production les plus évoluées garantissent des produits abrasifs du plus haut niveau de qualité.

Solutions innovantes

Les abrasifs sia sont perfectionnés en collaboration et selon les exigences des fabricants de peintures et laques pour l'industrie du meuble et de la carrosserie et par une analyse détaillée des matériaux à traiter. Ils représentent ainsi un travail suisse de haute précision et de qualité, avec pour objectif premier - l'obtention de surfaces parfaites.



sia Abrasives: State of the Art Production Facility
(Frauenfeld) Usine de production ultramoderne

TABLE OF CONTENTS

Sheets / Feuilles	(12 - 20)
Regular Sheets / Feuilles régulières	13
siafast Sheets / Feuilles siafast	15
siasoft Sheets / Feuilles siasoft	20
Accessories / Accessoires	Included / inclus
Belts / Bandes	(21 - 31)
Paper Belts / Bandes de papier	22
Cloth Belts / Bandes de toile	25
Accessories / Accessoires	Included / inclus
Rolls / Rouleaux	(32 - 38)
Regular Rolls / Rouleaux réguliers	33
siasoft Rolls / Rouleaux siasoft	35
siafast Rolls / Rouleaux siafast	35
PSA Rolls / Rouleaux PSA	36
Discs / Disques	(39 - 62)
Autoadhesive Discs / Disques autocollants	40
siafast Discs / Disques siafast	42
Regular Discs / Disques Réguliers	54
siafix Discs / Disques siafix	55
Fiber Discs / Disques de fibre	56
X-Lock Discs / Disques X-Lock	59
Flap Discs / Disques à lamelles	(61 - 64)
Accessories / Accessoires	Included / inclus
Bonded / Agglomérés	(65 - 68)
Cut-off wheels / Roues à couper	65
Grinding Wheels / Roues à ébarber	68
Nonwoven Abrasives / Non tissé	(69 - 81)
Hand Pads / Tampons	70
Belts / Bandes	71
Rolls / Rouleaux	72
Discs (siafast, plain, siafix)	73
Disques (siafast, régulier, siafix)	78
siastrip Discs / disques siastrip	78
Flap Discs / Disques a lamelles	79
Felt Discs / Disques de feutre	79
siamop / siamop (keeway)	81
Accessories / Accessoires	Included / inclus

TABLE DES MATIÈRES

Foam Abrasives / Éponges	(82 - 86)
STANDARD Pads / Tampons	83
FLAT Pads & Discs / Tampons & disques	84
FLEX Pads & Discs / Tampons & disques	85
SOFT & HARD Blocks / Blocs	86
Accessories / Accessoires	Included / inclus
Microtec / Microtec	(87 - 92)
Profile / Profilés	(93 - 95)
Pro-Core Wheels / Roues Pro-Core	94
Strips & Rolls for Vonnegut Wheels /	
Lamelles & roues pour roues Vonnegut	95
Brush / Brosses	(96 - 99)
Proflex Brushes / Brosses Proflex	97
Multi-Flex Brushes / Brosses Multi-Flex	98
Polishing / Polissage	(100 - 103)
siachrome Paste / Pâtes siachrome	101
Polishing Pads / Plateaux pour polir	102
Mating Paste / Pâte de mottage	103
Accessories / Accessoires	Included / inclus
Specialities / Spécialités	(104 - 109)
Spirabands / Manchons	104
Flap Wheels / Roues à languettes	106
Cartridge Rolls / Cartouches	108
Cross Pads / Tampons en croix	109
Accessories / Accessoires	Included / inclus
Accessories / Accessoires	(110 - 112)
siaklett Conversion / Conversion siaklett	111
Cleaning Cloths / Chiffons de nettoyage	112
Various / Autres	112
Sanding Technology /	
Techniques de ponçage	113
Grit use / Utilisation des grains	115

CONTACT US

Abrasifs J.J.S Inc. has two points of service. One based in Ontario & another one in Quebec.

Ontario office provides services to customers from Ontario to Western Canada

Quebec office serves customers from Quebec to Eastern Canada

NOUS REJOINDRE

Abrasifs J.J.S Inc. offre deux points de services dont un situé au Québec et l'autre en Ontario.

Le bureau du Québec dessert le Québec et l'est canadien

Celui de l'Ontario reçoit les demandes provenant de l'Ontario et de l'ouest canadien.

JJS Canada Inc.

ONTARIO/WEST CANADA

📍 1251 Gorham Street, Unit 11
Newmarket (ON) | L3Y 8Y6

📞 +1 800 337-1325

📞 +1 905 898-0116

✉️ orderdesk@jjscanada.ca

🌐 jjscanada.ca

JJS Canada Inc.

QUEBEC

📍 900 chemin Olivier,
Levis(QC) | G7A 2N1

📞 +1 800 463-1574

📞 +1 418 836-0557

✉️ commandes@jjscanada.ca

🌐 jjscanada.ca

JJS Canada Inc.

ONTARIO / OUEST DU CANADA

📍 1251 Gorham Street, unité 11,
Newmarket, ON, L3Y 8Y6

📞 +1 800 337-1325

📞 +1 905 898-0116

✉️ orderdesk@jjscanada.ca

🌐 jjscanada.ca

JJS Canada Inc.

QUÉBEC

📍 900 Chemin Olivier,
Lévis, QC, G7A 2N1

📞 +1 800 463-1574

📞 +1 418 836-0557

✉️ commandes@jjscanada.ca

🌐 jjscanada.ca

SALES TEAM - MANAGEMENT - ÉQUIPE DES VENTES

Abrasives JJS technical representative team is composed of **11 abrasive specialists supported by 5 customer service agents.**

This team is supervised by two seasoned managers.

Do not hesitate to contact them!

Notre équipe de représentants techniques est constituée de **11 spécialistes en abrasifs aidés de 5 conseillers au service à la clientèle.**

Cette équipe est supervisée par deux personnes d'expérience.

N'hésitez pas à communiquer avec eux!



Ontario & Western Canada
Ontario & ouest canadien

Paul McIntyre

Directeur régional des ventes
Regional Sales Manager

pmcintyre@jjscanada.ca



Québec & Eastern Canada
Quebec et l'est canadien

Simon Patry

Directeur régional des ventes
Regional Sales Manager

spatry@jjscanada.ca

Business Hours / Heure d'ouvertures

Monday to Thursday

Lundi au jeudi

8:00 - 16:30

Friday

Vendredi:

8:00 - 16:00

(EST / heure de l'est)



Votre source de solutions
Your Solution Partner



jjscanada.ca

PART NUMBER

Product numbers are composed of 12 digits. The first 8 digits are the product number *per se* and the last 4 indicates its grit or grade.



List of available grits for a particular product is indicated at the end of the table.

NUMÉRO DE PRODUIT

Les numéros de produits sont composés de 12 caractères. Les 8 premiers correspondent au produit et les 4 suivants au grain ou au grade du produit.

La liste de grains disponibles pour un produit donné est montrée à la fin de chaque tableau.

EXAMPLE / EXEMPLE

1960 siarexx Cut		Aluminum Oxide (paper) - Corindon (papier)			
	Size Dimension	Grit Grain	Part Number Numéro de produit	Qty / case Qté / caisse	Qty / sleeve Qté / paquet
	9" x 11" (230 x 280 mm)	040	1074.3042.xx40	250	25
		050 - 080	1074.3042.xxxx	250	50
		100 - 150	1074.3042.xxxx	500	50
		180 - 600	1074.3042.xxxx	500	100
	4-1/2" x 11" (115 x 280 mm)	040 - 060	8330.1258.xxxx	500	50
		080 - 400	8330.1258.xxxx	600	100
	3-2/3" x 9" (230 x 280 mm)	040 - 060	5025.2530.xxxx	500	50
		080 - 320	5025.2530.xxxx	600	100

Grits / Grains: 40, 50, 60, 80, 100, 120, 150, 180, 220, 240, 280, 320, 400, 500, 600

1074.3042 . XXXX

Product Number . Grit / Grade
Numéro de produit . Grain / Grade

For the 600 grit: # 1074.3042.0600
Pour le grain 600:

For the 80 grit: # 1074.3042.0080
Pour le grain 80:

SERIES NUMBER

NUMÉRO DE SÉRIE

The series number is composed of 4 digits. The first digit indicates the backing, the second one is the type of grain and the 2 last digits are to differentiate series having similar composition.

Les numéros de séries sont composés de 4 chiffres. Le premier correspond au support utilisé, le deuxième au type de grain tandis que les deux derniers servent à différencier les séries ayant une composition semblable.

	Backing / support		Grain / Grain
1xxx	Paper / Papier	x2xx	Diamond / Diamant
2xxx	Cloth / Toile	x4xx	Garnet - Ruby / Grenat - rubis
3xxx	Combination / Combinaison	x5xx	Ceramic / Céramique
4xxx	Carbon Fiber / Fibre de carbone	x6xx	Emery / Émeri
5xxx	Film / Film	x7xx	Silicon Carbide / Carbure de silicium
6xxx	Nonwoven / Matériel non tissé	x8xx	Zirconia - Alox / Zirconium - corindon
7xxx	Net / Treillis	x9xx	Aluminum Oxide / Corindon
8xxx	Bonded / Aggloméré		

Example / exemple: 19xx : Paper / Alox. - Papier / Corindon
75xx : Net / Ceramic - Treillis / Céramique

Coated Abrasives
Abrasifs liés

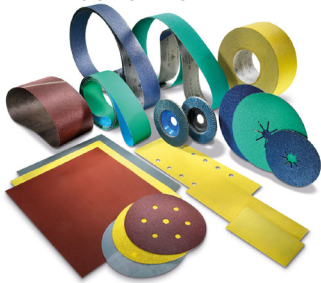

Bonded Abrasives
Abrasifs Agglomérés

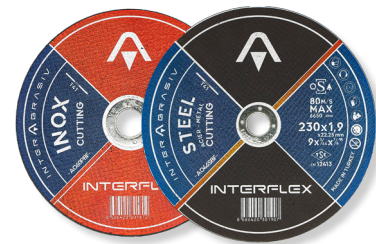

Micro Abrasives
Microabrasifs

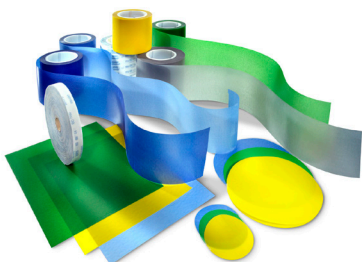

Nonwoven Abrasives
Abrasifs non liés



Foam Abrasives
Abrasifs en mousse



TERMS AND CONDITIONS

PRICES: All prices are subject to change without notice. All quotes are firm for 30 days only.

TERMS: Net 30 days. Invoices not paid within 30 days would result of holding other orders. Collection fees will be added to all accounts placed for collection. Items may also be shipped COD.

MINIMUM ORDER: See specific items for minimum order. Total order amount must be one hundred dollars (\$100) shipped to a single destination.

QUANTITY SHIPPED: Quantity shipped may vary for a maximum of ten percent (10%) of the original order.

SALE TAXES: Sale taxes are added when applicable.

RETURNED GOODS: No material can be returned without prior written authorization from Abrasifs J.J.S Inc. All authorized returns must be sent prepaid. Abrasifs J.J.S Inc. will not accept returns with unpaid freights. Claims for loss or damage in transit must be made by writing to Abrasifs J.J.S Inc. within 15 days of invoice date. Authorized returns are subject to 15 % restocking fees. Material found to be defective after examination will be credited to the customer. In addition, prepaid transportation will be refund on defective materials.

MODALITÉS ET CONDITIONS

LES PRIX: Les prix sont sujets à changement sans préavis. Tous les prix provenant d'une soumission sont assurés durant 30 jours seulement.

CONDITIONS DE PAIEMENT: Net 30 jours. Les commandes impayées après 30 jours peuvent provoquer l'arrêt des commandes subséquentes. Des frais de collection peuvent être ajoutés aux comptes en souffrance. Les items peuvent aussi être envoyés en COD.

COMMANDE MINIMUM: Voir les quantités minimales assujetties à chacun des items. Le montant d'une commande pour une destination doit être d'au moins cent dollars (100 \$).

QUANTITÉ LIVRÉE: Les quantités livrées peuvent varier d'un maximum de dix pourcent (10%) de la commande originale.

TAXES DE VENTE: Les taxes de vente sont en sus le cas échéant.

RETOUR DE MARCHANDISE: Aucune marchandise ne peut être retournée sans l'accord écrit de Abrasifs J.J.S. Inc. Les frais de transport de la marchandise retournée sont à la charge du client. Abrasifs J.J.S. Inc. n'acceptera pas de retour de marchandise si le transport n'est pas payé d'avance. Les réclamations doivent être faites par écrit à Abrasifs J.J.S. Inc. à l'intérieur d'un délai de 15 jours suivant la date de la facture. La marchandise acceptée pour retour fera l'objet d'une facturation de remise en stock de 15 %. Lorsque la marchandise est retournée pour cause de défectuosité et que celle-ci s'avère véritable, elle fera l'objet d'un crédit sans retenu au client. De plus, il y aura remboursement des frais de transport payés d'avance par le client.

LOSS \ DAMAGED MERCHANDISE: Transportation companies assume all liability from the time a shipment is picked up by them until it is delivered to the customer. Abrasifs J.J.S Inc. liability ceases at the time of shipment. Claims for loss or damaged merchandise must be directly made to the delivering carrier.

ADD-ON POLICY: Stock items may be added to an order as long as the original order remains unshipped. Freight and pricing for the additions will be treated the same way as the original order.

CANCELLATION CHARGES: Any orders cancelled as requested by a customer, will be charged to the customer at a price equal to the cost of the material, labour and factory overhead incurred by Abrasifs J.J.S Inc. up to the stage of production reached at the time of cancellation.

CUSTOMER REWORK: There will be an hourly rate charged for the work performed on customer's material. Rate will be available upon request. Shipping fees are paid by customers. All work performed will be at the client's risk.

SIA ABRASIVES PRODUCTS SOLD BY ABRASIVES JJS ARE ONLY DESTINATED TO THE CANADIAN MARKET. RESELL TO THE USA IS FORBIDDEN.

MARCHANDISE PERDUE OU ENDOMMAGÉE: Les compagnies de transport assument la responsabilité de la marchandise à partir du moment où elles la reçoivent jusqu'au moment où elles la livrent à destination. La responsabilité de Abrasifs J.J.S. Inc. cesse au moment où la cargaison est transférée au transporteur. Toutes réclamations pour perte ou dommage de matériel en cours de route doivent être faites auprès dudit transporteur par le consignataire.

PRATIQUES CONCERNANT LES ARTICLES AJOUTÉS: Il est possible d'ajouter des articles conservés en stock à une commande aussi longtemps que la commande originale n'a pas été expédiée. Le prix et les frais pour les additions seront traités de la même manière que pour la commande originale.

ANNULATION: Toute commande annulée à la demande du client sera facturée au client à un prix égal au coût des matières, de la main d'œuvre et des frais généraux de production encourus par Abrasifs J.J.S. Inc. jusqu'au stade de production atteint par la compagnie au moment de l'annulation.

TRAVAUX DE CONDITIONNEMENT SUR DU MATÉRIEL PROVENANT DES CLIENTS: Les travaux exécutés sur les matériaux provenant des clients feront l'objet d'une facturation de soixante dollars (60 \$) par heure de travail. Les frais de transport sont à la charge du client. Tous ces travaux sont effectués aux risques du client.

LES PRODUITS SIA ABRASIVES VENDUS PAR ABRASIFS JJS SONT UNIQUEMENT DESTINÉS AU MARCHÉ CANADIEN. IL EST INTERDIT DE LES REVENDRE AUX USA.

ORDERS

Same Day Orders

Abrasifs J.J.S Inc. offers a personalized service to meet your specific needs.

We ship your order the **same day if the order was placed before 10:00 a.m.** (Eastern time). This service is applicable only for stock products. There are no additional charge for this service.

Order Processing

As soon as your order is placed, you will receive an e-mail (or fax) confirmation of your order. Please, read it carefully to avoid any mistakes, including the ship-to address. If errors are found or you wish to modify your order, contact us immediately by phone and we will do our best to accommodate you.

**In the case of a verbal order, the order confirmation is the only document which confirms details of the sale. This document must to be checked by the customer to avoid any mistakes and return charges on the delivered goods.*

LES COMMANDES

Commandes traitées la même journée

sia Abrasifs J.J.S Inc. offre un service personnalisé afin de rencontrer vos besoins spécifiques.

Votre commande est traitée la même journée si celle-ci est déposée avant 10:00 a.m. (heure de l'est). Ce service s'applique pour les produits disponibles et aucune charge additionnelle ne sera imposée pour ce service.

Traitement des commandes

Peu de temps après avoir passé votre commande, vous recevrez un courriel (ou télécopie) de confirmation de commande. Veuillez vous assurer qu'elle ne contient pas d'erreurs, notamment dans l'adresse d'expédition. En cas d'erreur ou si vous souhaitez modifier votre commande, communiquez avec nous immédiatement par téléphone et nous ferons tout en notre pouvoir pour donner suite à votre appel.

**Dans le cas d'une commande verbale, la confirmation de commande est le seul document qui confirme les détails de la vente. Ce document doit donc être revérifié par le client afin d'éviter des frais de retour sur la marchandise livrée.*

NON-STOCK PRODUCTS

We sell the entire line of coated abrasives from which several products are not listed in the present catalogue.

Do not hesitate to contact us to get more information about abrasive products. We will strive to meet your particular needs.

PRODUITS NON-STANDARDS

Nous vendons une gamme complète d'abrasifs dont plusieurs ne sont pas inclus dans le présent catalogue.

N'hésitez pas à communiquer avec nous pour tous besoins en matériels abrasifs. Nous avons probablement ce qu'il vous faut.

PART INDEX

INDEX DES PRODUITS

		Part number	Page			Part number	Page
		No. produit				No. produit	
BC.1000	112	062F.7558	41	0020.3285	49	0020.9147	53
C138E	105	063F.1724	53	0020.3453	48	0020.9299	50,103
FE.9063	31	064F.6319	53	0020.3713	15	0020.9404-05	101
GG.3132L	30	066F.1327	49	0020.3718	58	0020.9560-67	60
GG.3132R	30	067F.0200	52	0020.3720	58	0021.C001-10	64,78
GG.3134	30	067F.2997	49	0020.3925	112	0021.C011-14	79
GR.303	30	072E	63	0020.3983	112	0021.C015-16	79
GR.450	30	073E	63	0020.4174	103	0033.9073	23
GR.HD	30	074E	63	0020.4323-25	63	0044.8005	43
PU.9165	31	075E	63	0020.4361-65	63	0069.2541	34
QL-808-4848	105	076E	63	0020.4373-77	63	0070.0473	83
RA.1919	31	077E	63	0020.4387-91	63	0070.0480	83
RL	106	114F.0100	58	0020.4399-03	63	0070.0468-69	83
Z506.0047	63	132F.0019	41	0020.4409-12	63	0070.1228	86
003F.0125	41	511M.7118	38	0020.4546	53	0070.1230	86
004A.4673	112	631F.0115	75	0020.4740	51,86	0070.1233	86
004F.9163	41	632F.0125	75	0020.4744	51	0070.1234-35	85
005F.6817	50	633F.0180	75	0020.4900-01	63	0070.1241-42	86
009N.1349	20	905B.0051-81	112	0020.5456-57	63	0070.1247	85
016J.4689	19	971K.3321	75	0020.5740-42	52	0070.1249-52	85
021F.7111	51	998L.0125	103	0020.5771-72	63	0070.1253-55	86
022F.4268	50	0020.0016	112	0020.5886	53	0070.1260	86
023N.6701	14	0020.0073	51,103	0020.6514-17	19	0070.1396-99	85
025F.6304	50	0020.0088	112	0020.6518	19	0070.1402	84
026N.3267	13	0020.0095	19	0020.6663-67	101	0070.1404	84
027F.2673	51	0020.0113	66	0020.6668	102	0070.1408	84
030U.3178	50	0020.0180-83	52,75	0020.6670	103,112	0070.1409-12	85
030P.2449	97	0020.0269	53	0020.6671-74	101	0070.1597-1601	84
030P.3667	97	0020.0325	31	0020.6675-76	102	0070.1602-06	84
030P.4579	97	0020.0342	19	0020.6728-29	51	0070.1673	84
030P.5519	97	0020.0343	19	0020.6730-31	50	0070.1675	84
030P.5798	97	0020.0345	51,86	0020.6732-33	41	0070.9575	84
030P.6825	97	0020.0346	51	0020.6734-35	51	0222.1827	57
030P.9972	97	0020.0357	52	0020.6736-37	51	0256.9093	27
031U.1286	52	0020.0364	49	0020.6738-39	41	0264.3689	33
032N.9903	13	0020.0377	94	0020.6741	103	0274.8350	47
032U.2283	50	0020.0379	94	0020.7045	19	0330.7046	111
036F.7883	49	0020.0389	15	0020.7383	102	0364.8361	27
036N.0214	14	0020.0431-32	58	0020.7384	101	0388.1861	34
037F.7984	49	0020.0537	50	0020.7428	53	0423.4783	60,78
037N.8011	14	0020.0539-40	50	0020.7858	53	0430.8219	34
038F.7987	49	0020.0556-57	31	0020.7620-22	75	0439.5603	16
041L.6629	103	0020.1086	66	0020.8063-80	56,77	0441.8605	57
042L.1821	103	0020.1839	50,103	0020.8123	53,103	0456.8174	74
043L.6124	102	0020.1988	103	0020.8124	53	0465.4240	16
043N.5523	14	0020.2045	50	0020.8259	53,103	0485.5668	34
044L.4263	102	0020.2301-02	112	0020.8418-20	58	0514.8296	41
045L.2779	102	0020.2325	75	0020.8716-34	66	0524.1027	26
046L.1834	102	0020.2651-61	63	0020.8727	67	0546.3989	55,77
047L.8367	102	0020.2922-24	63	0020.8735-36	68	0596.3968	111
048L.9144	102	0020.3021-23	63	0020.8737-41	67	0621.0307	31
049L.6632	102	0020.3025-28	63	0020.8742-45	60	0639.7965	26
050F.1257	49	0020.3185	103,112	0020.8912-19	60	0643.1561	60,78
050L.8177	102	0020.3193	53	0020.9041-54	81		

PART INDEX

INDEX DES PRODUITS

Part number No. produit	Page	Part number No. produit	Page	Part number No. produit	Page	Part number No. produit	Page
0662.2534	34	1857.8489	76	3327.8302	57	4557.8729	111
0663.3146	27	1924.6535	34	3361.8166	14	4564.0566	20
0678.1224	111	1935.3923	57	3384.1159	40	4582.3519	111
0681.2776	18	1965.7045	55,77	3395.6683	26	4641.5949	54
0725.8806	28	2003.9126	54	3415.8417	34	4661.8394	27
0748.0314	23	2017.3677	23	3429.9839	18	4676.1834	74
0779.9568	94	2068.1904	23	3433.4298	26	4680.0076	73
0785.1011	14	2070.5556	43	3479.2740	18	4696.4167	27
0798.0972	43	2073.6558	76	3491.8290	28	4730.0831	71
0801.0225	111	2099.0897	27	3506.0088	55,77	4763.0178	57
0824.4837	27	2166.9718	18	3517.8839	36	4818.6559	14
0829.5083	111	2183.4994	40	3596.0911	35	4833.2982	27
0845.6297	46	2189.9476	35	3605.2103	26	4852.8276	23
0863.4800	18	2197.5101	40	3634.8579	26	4880.2269	33
0948.3321	70	2214.3791	28	3636.6530	36	4880.3461	23
0983.5066	74	2234.7823	47	3646.1028	23	4881.0209	48
0986.0338	34	2237.4334	35	3647.2462	48	4895.8612	74
1008.8936	23	2242.7566	55,78	3650.1158	43	4917.8786	54
1014.3429	111	2250.9187	43	3703.0148	41	5002.6471	46
1039.9669	28	2327.4387	26	3714.9438	26	5013.8691	43
1048.4405	14	2334.4285	26	3729.6263	28	5014.2229	36
1061.4366	47	2337.2058	74	3752.5933	36	5016.4703	47
1064.0241	41	2344.9555	72	3771.8241	14	5052.5920	26
1070.7334	16	2375.1788	54	3817.0427	46	5056.3994	43
1073.9713	55,77	2404.8349	23	3854.6295	57	5056.9856	33
1127.6993	26	2477.1960	34	3855.8589	14	5060.0926	26
1180.7962	111	2503.3501	27	3869.7936	43	5074.1848	54
1194.2874	23	2531.0406	23	3886.3796	46	5096.6824	36
1224.7005	23	2546.9964	33	3902.0030	27	5115.4528	54
1236.7347	46	2611.8981	58	3933.3104	40	5163.3687	48
1270.8925	46	2613.2197	28	3983.8368	23	5332.3986	23
1278.5025	57	2698.1717	28	4057.1006	23	5349.3433	111
1296.8440	23	2844.4474	111	4085.0148	46	5351.4789	28
1300.5174	28	2849.9871	13	4114.0225	54	5369.8301	57
1416.5100	55,77	2866.4928	28	4132.9840	70	5404.1437	45
1423.2879	18	2899.6168	28	4134.8685	27	5439.3639	23
1426.9972	57	2917.2391	26	4140.6699	95	5445.4510	54
1438.4338	111	2956.8143	55,77	4152.4162	54	5557.1958	26
1457.8459	26	2969.2150	36	4227.3354	26	5557.6942	111
1470.6044	41	2981.4558	33	4233.0006	57	5559.2718	40
1476.3402	54	3038.0034	28	4269.7970	43	5611.8791	95
1478.6494	71	3041.7440	23	4278.6885	28	5645.0310	23
1520.4046	43	3064.3952	111	4366.8648	16	5645.6768	76
1545.0741	26	3081.7733	28	4372.6660	40	5658.8476	13
1546.3150	46	3100.3713	14	4415.8289	36	5659.4836	40
1635.2907	36	3112.6623	34	4418.9881	43	5664.6473	54
1707.8418	23	3112.2714	34	4432.6606	33	5706.9694	40
1715.2309	55,78	3135.1630	57	4439.0713	23	5712.4043	57
1736.2582	45	3204.7084	111	4446.8229	34	5730.7754	47
1737.3366	57	3210.1376	16	4460.3298	73	5762.4767	28
1743.4147	26	3211.3994	23	4497.5722	23	5791.1543	26
1762.1219	47	3216.2553	71	4516.5708	20	5797.3499	94,111
1786.4529	23	3233.2914	27	4543.3400	57	5814.0290	73
1847.6064	54	3281.1275	33	4546.6124	54	5816.8425	46

PART INDEX

INDEX DES PRODUITS

		Part number	Page				
		No. produit					
5863.3581	40	6783.7705	46	8024.2860	28	9453.3739	48
5869.5710	48	6783.9190	16	8037.6118	26	9495.3729	47
5869.7195	18	6795.8864	26	8036.2137	71	9515.8032	17
5870.5126	41	6849.2154	26	8072.1424	26	9519.0126	18
5903.6105	55,77	6914.2253	27	8166.0152	18	9555.9679	23
5980.9923	16	6931.5791	26	8185.7250	54	9562.9761	23
5994.6657	111	6931.4980	23	8187.1992	34	9569.8280	60
5999.2077-80	78	6938.1114	26	8239.3460	43	9692.0437	111
5999.2101-09	55,77	6999.5774	47	8286.8318	46	9715.0507	47
5999.2128-29	78	6999.7726	18	8314.0259	55,77	9789.5058	60
5999.2168-69	78	7025.6097	57	8377.8251	47	9834.8246	26
5999.2192-95	78	7088.2671	111	8386.6272	43	9879.5847	57
6029.8826	74	7088.4966	111	8390.6852	43	9931.2213	34
6056.8709	27	7088.6933	111	8438.1710	46	9934.5871	27
6096.7887	111	7111.8012	43	8443.7842	46	9947.7255	20
6102.6526	16	7120.5813	57	8447.2356	34	9967.9911	48
6123.2545	43	7124.2139	28	8451.8686	48	9980.9463	48
6124.3627	28	7159.2870	46	8466.9397	46	9997.8004	40
6144.4474	27	7181.8265	48	8486.4459	48		
6152.0922	28	7182.0217	18	8502.6854	47		
6202.6692	47	7184.2947	54	8539.5549	27		
6208.6781	40	7190.4609	44	8555.1624	34		
6214.1398	18	7192.0485	23	8559.3479	26		
6214.8985	48	7202.1331	23	8612.7001	55,78		
6250.9329	28	7220.7194	26	8633.7741	45		
6256.1639	40	7245.2875	57	8654.0246	47		
6269.3860	20	7256.1066	27	8734.9195	54		
6274.3623	111	7285.4325	43	8739.0458	23		
6329.7598	18	7309.8603	43	8741.1479	23		
6330.4059	111	7332.9183	46	8745.2635	26		
6345.6862	23	7340.2591	57	8777.2883	40		
6368.1182	23	7498.8090	43	8843.2298	23		
6390.9305	40	7523.1175	23	8859.3479	26		
6393.5966	26	7526.3953	18	8863.2204	55,77		
6397.0967	48	7546.2948	46	8907.3244	27		
6452.8050	55,77	7548.7719	47	8926.4909	26		
6482.1538	26	7594.3912	23	8947.8868	27		
6491.3271	27	7606.3129	41	9015.2364	47		
6525.3859	71	7608.9528	47	9049.2842	74		
6529.9916	43	7621.1023	35	9064.8944	47		
6559.0540	111	7626.1883	33	9133.1796	23		
6564.0927	46	7674.6859	27	9140.2725	55,78		
6581.1109	35	7703.3262	23	9142.8492	111		
6581.2131	111	7709.3989	48	9232.2743	41		
6617.3581	26	7711.8671	54	9245.5238	31		
6640.4283	94,111	7714.6626	45	9268.9620	74		
6650.8269	43	7749.2159	43	9302.4256	23		
6662.8885	44	7765.3900	40	9316.8917	36		
6715.2236	57	7810.2448	23	9326.4828	40		
6715.2881	33	7828.6306	47	9327.7238	72		
6728.3559	27	7866.2539	76	9335.3603	48		
6736.2380	43	7994.2898	23	9347.4354	16		
6736.4332	16	8007.5094	27	9404.9822	23		
6751.8637	47	8023.0581	48	9408.6556	28		

One Strip for 2 Sizes of Hand Pads Une feuille coupée pour 2 dimensions de blocs

2-3/4" x 7-13/16" (70 x 198 mm)
Page 19



2-3/4" x 15-3/4" (70 x 400 mm)
Page 19



New assortment of flapdiscs - Nouvelle gamme de disques à lamelles

2500

(Ceramic / Céramique)

The innovative abrasive for a fast removal rate

L'abrasif innovant pour un enlèvement de matière rapide

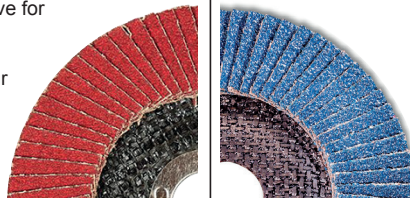

2824 siaflap Eco

(Zirconia / Zirconium)

High-performance flap discs for high-alloy steel

Disques performants pour l'acier hautement allié

2824 siaflap Jumbo

(Zirconia / Zirconium)

A high-performance product for industrial needs.

Produit performant destiné à l'industrie



2824 siaflap Standard

(Zirconia / Zirconium)

A tool for series processing with very high strength.

Outil haute résistance pour l'usinage en série



1719 sialac

Silicon carbide, stearate
Carbure de silicium, stéarate

P180 - P800

Water base lacquers
Laques à base aqueuse



Aluminum Oxide
Oxide d'aluminium

P180 - P600

PU-lacquers, melamine
Laques PE, mélamine



1730 sialac

Silicon carbide
Carbure de silicium

P180 - P800

UV-lacquers, melamine
Laques UV, mélamine



SCM Discs with Tear-off Center Hole Disque SCM avec trou central détachable

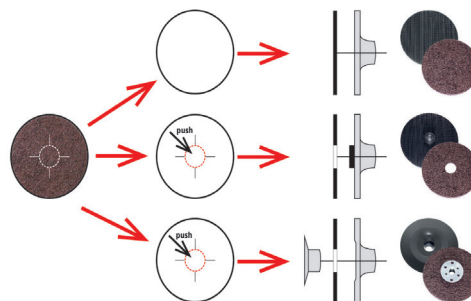

NEW PRODUCTS

NOUVEAUX PRODUITS

siapro 1958

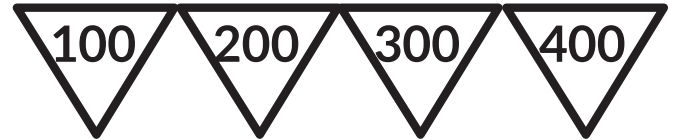

100		200		300		400		800 / 100			
(80 - 150)	(180 - 240)	(280 - 320)	(360 - 500)	(600 - 1000)							
Body fillers - Mastics				Primer fillers - Apprêts				Lacquers - Lacques			
For aggressive cut (Levelling)		For speed (finishing)		For straight cut (levelling)		For high surface quality (finishing)		For scuffing (superfinishing)			
Pour une coupe agressive (planage)		Pour rapidité (finition)		Pour un coupe uniforme (planage)		Pour une surface de qualité (finition)		Pour mattage (superfinition)			

siaperformance

Core Zone / Zone centrale

More holes in the centre for maximum dust extraction.
Plus de trous au centre pour une aspiration maximale.

For convenient, simple mounting.
Pour montage commode, simple.

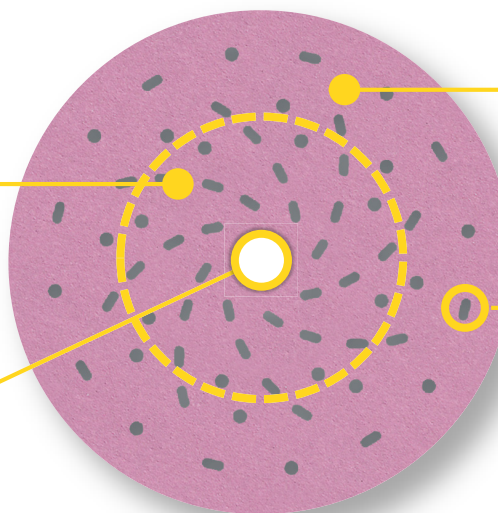

Outside Area / Espace extérieur

Fewer holes outside the core zone for optimum air flow into the centre.
Moins de trous à l'extérieur de la zone centrale pour un écoulement optimal de l'air vers le centre.

Slotted Holes / Troux à fentes

Extraction is optimised thanks to the larger extraction surface of the slotted holes.
L'extraction est optimisée grâce à une plus grande surface d'extraction avec des trous à fentes.



SHEETS AND STRIPS
FEUILLES ET COUPES

Series Available in Plain Sheets ponibles pour les feuilles régulières

Séries dis-

Series Série	Grit Range Granulométrie	Type of Grit Type de grain	Type of Backing Type de support	Applications Applications
1713 siawat	80 - 2500	Silicon carb. Carb. silicium	C-Paper (waterproof) Papier (impermeable)	Composites, body shop, aluminum, waterproof Composites, carrosserie, alum., imperméable
1786 siagypse	80 - 150	Silicon carb. Carb. silicium	Paper Papier	Gypse Placoplâtre
1913 siawat fc	60 - 2500	Aluminum Ox. Corindon	B/C-Paper Papier-B/C	Composites, body shop, waterproof Composites, carrosserie, imperméable
1902 siacraft	40 - 240	Aluminum Ox. Corindon	C-Paper Papier-C	Woods (solid, varnished), hand sanding Bois (solide, vernis), ponçage manuel
1948 siaflex	40 - 800	Aluminum Ox. Corindon	Latex Latex	Metals, fiberglass, fillers, aluminum, steel Métaux, fibre de verre, mastics, alum, acier
1960 siarexx	40 - 600	Aluminum Ox. Corindon	C/B-Paper Papier-C/B	Woods (solid, varnished) Bois (solide, vernis)
2680 sianor j	60 - 120	Emery Émeri	Cloth Toile	Metals Métaux
2915 siarol	40 - 400	Aluminum Ox. Corindon	j-Cloth Toile-j	Metals Métaux
7000 siascreen	60 - 220	Aluminum Ox. Corindon	Screen Treillis	Gypse Placoplâtre

Accessories for Plain Sheet Are Shown on Page 15
Les accessoires pour les feuilles régulières sont situés à la page 15

Plain Sheets - Feuilles régulières

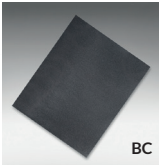
1713 siawat	Silicone Carbide (waterproof) Carbure silicium (hydrofuge)				
	Size Dimension	Grit Grain	Part Number Num produit	Case Caisse	Sleeve Paquet
BC	9" x 11" (230 x 280 mm)	080 - 120	5658.8476.xxxx	250	50
		150 - 2500	5658.8476.xxxx	500	50

Grit / Grain: 80, 100, 120, 150, 180, 220, 240, 280, 320, 400, 500, 600, 800, 1000, 1200, 1500, 2000, 2500

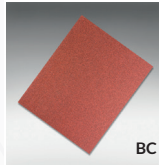
1902 siacraft	Aluminum Oxide (papier) Corindon (papier)				
	Size Dimension	Grit Grain	Part Number Num produit	Case Caisse	Sleeve Paquet
BC	9" x 11" (230 x 280 mm)	40 - 240	2849.9871.xxxx		50

Grit / Grain: 40, 60, 80, 100, 120, 150, 180, 220, 240

1786 siagypse	Silicone Carbide (paper) Carbure silicium (papier)				
	Size Dimension	Grit Grain	Part Number Num produit	Case Caisse	Sleeve Paquet
BC	3-5/16" x 11" (85 x 280 mm)	080 - 150	026N.3267.xxxx	500	25
	4-3/16" x 11" (110 x 280 mm)	080 - 150	032N.9903.xxxx	500	25

Grit / Grain: 80, 100, 120, 150



1713 siawat

Plain Sheets - Feuilles régulières

1913 siawat Aluminum Oxide (waterproof)
Corindon (hydrofuge)

Size Dimension	Grit Grain	Part Number Num produit	Case Caisse	Sleeve Paquet
9" x 11" (230 x 280 mm)	060 - 150	3100.3713.xxxx	250	50
	180 - 1200	3100.3713.xxxx	500	50
	1500 - 2500	3100.3713.xxxx	500	50

Grit / Grain: Silicone carbide / carbure silicium: 1500, 2000, 2500

Grit / Grain: Aluminum Oxide / corindon: 60, 80, 100, 120, 150, 180, 220, 240, 280, 320, 400, 500, 600, 800, 1000, 1200

Film backing for grits from 800 to 1500
Support sur film pour les grains de 800 à 1500

1948 siaflex Aluminum Oxide (latex)
Corindon (latex)

Size Dimension	Grit Grain	Part Number Num produit	Case Caisse	Sleeve Paquet
9" x 11" (230 x 280 mm)	040	0785.1011.0040	100	25
	060 - 150	0785.1011.xxxx	250	50
	180 - 600	0785.1011.xxxx	500	50
	800	3855.8589.0800	500	50

Grit / Grain: 40, 60, 80, 100, 120, 150, 180, 220, 240, 280, 320, 400, 500, 600, 800

1960 siarexx Aluminum Oxide (paper)
Corindon (papier)

Size Dimension	Grit Grain	Part Number Num produit	Case Caisse	Sleeve Paquet
9" x 11" (230 x 280 mm)	040	1048.4405.0040	250	25
	050 - 080	1048.4405.xxxx	250	50
	100 - 150	1048.4405.xxxx	500	50
	180 - 600	1048.4405.xxxx	500	100

Grit / Grain: 40, 50, 60, 80, 100, 120, 150, 180, 220, 240, 280, 320, 400, 500

1960 siarexx Aluminum Oxide (paper)
Corindon (papier)

Size Dimension	Grit Grain	Part Number Num produit	Case Caisse	Sleeve Paquet
3-5/16" x 11" (85 x 280 mm)	100 - 220	3361.8166.xxxx	500	100
4-3/16" x 11" (107 x 281 mm)	080 - 220	3771.8241.xxxx	500	100

Grit / Grain: 80, 100, 120, 150, 180, 220



2680 sianor j Emery (cloth)
Éméri (toile)

Size Dimension	Grit Grain	Part Number Num produit	Case Caisse	Sleeve Paquet
9" x 11" (230 x 280 mm)	60 (coarse / rude)	023N.6701.0060	500	50
	80 (medium / moyen)	023N.6701.0080	500	50
	120 (fine / fin)	023N.6701.0120	500	50

Grit / Grain: 60, 80, 120

2915 siarol Aluminum Oxide (cloth)
Corindon (toile)

Size Dimension	Grit Grain	Part Number Num produit	Case Caisse	Sleeve Paquet
9" x 11" (230 x 280 mm)	040	4818.6559.xxxx	100	25
	060 - 400	4818.6559.xxxx	250	25

Grit / Grain: 40, 60, 80, 100, 120, 150, 180, 220, 240, 280, 320, 400

7000 siascreen Silicone Carbide (screen)
Carbure silicium (treillis)

Size Dimension	Grit Grain	Part Number Num produit	Case Caisse	Sleeve Paquet
3-5/16" x 11" (85 x 280 mm)	080 - 220	036N.0214.xxxx	500	50
4-3/16" x 11" (110 x 280 mm)	080 - 220	037N.8011.xxxx	500	50



Grit / Grain: 80, 100, 120, 150, 180, 220

7000 siascreen Silicone Carbide (screen)
Carbure silicium (treillis)

Size Dimension	Grit Grain	Part Number Num produit	Case Caisse	Sleeve Paquet
9" x 11" (230 x 280 mm)	060 - 180	043N.5523.xxxx	250	50

Grit / Grain: 60, 80, 100, 120, 150, 180

Accessories for Plain Sheets (without siafast) Les accessoires pour les feuilles régulières (sans siafast)

0020.0389	Rubber Block Bloc en caoutchouc	0020.3713	Flexible Block (soft & extra soft) Bloc flexible (souple & extra souple)
 <p>2-3/4" x 5" (70 x 125 mm)</p>		 <p>2-3/8" x 5" (60 x 128 mm)</p>	



Series Available in siafast Sheets ponibles pour les feuilles siafast

Séries dis-

Series Série	Grit Range Granulométrie	Type of Grit Type de grain	Type of Backing Type de support	Applications Applications
1913 siawat fc	180 - 2500	Aluminum Ox. Corindon	C/D-Paper Papier-C/D	Metals, fillers, waterproof Métaux, mastiques, imperméable
1948 siaflex	40 - 800	Aluminum Ox. Corindon	Latex Latex	Metals, fiberglass, fillers, aluminum, steel Métaux, fibre de verre, mastics, alum, acier
1950 siaspeed	40 - 1500	Aluminum Ox. Corindon	Paper Papier	Metals, fiberglass, fillers, Métaux, fibre de verre, mastics
1960 siarexx	40 - 600	Aluminum Ox. Corindon	C/B-Paper Papier-C/B	Woods (solid, varnished) Bois (solide, vernis)
7500 sianet - CER	80 - 400	Ceramic Céramique	Screen Treilli	Wood, Varnish, Gypse Bois, vernis, Placoplâtre
7900 sianet	80 - 400	Aluminum Ox. Corindon	Screen Treilli	Wood, Varnish, Gypse Bois, vernis, Placoplâtre
7940 siaair	360 - 4000	Aluminum Ox. Corindon	3-D net Filet 3-D	body shop, woods Carrosserie, bois

Accessories for siafast Sheet are Shown on Page 19
Les accessoires pour les feuilles siafast sont disponibles à la page 19

siafast Sheets (H&L) - Feuilles siafast (auto-agrippant)

1913 siawat Aluminum Oxide (waterproof) Corindon (hydrofuge)

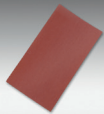
	Size Dimension	Grit Grain	Part Number Num produit	Case Caisse	Sleeve Paquet
	2-3/4" x 5" (70 x 125 mm)	0180 - 1200	5980.9923.xxxx	500	50
		1500 - 2500	5980.9923.xxxx	500	50

Grit / Grain: Silicone carbide / carbure silicium: 1500, 2000, 2500

Grit / Grain: Al. Ox. / corindon: 180, 220, 240, 280, 320, 400, 500, 600, 800, 1000, 1200

Film backing for grits from 800 to 1500
Support sur film pour les grains de 800 à 1500

1948 siaflex Aluminum Oxide (latex) Corindon (latex)

	Size Dimension	Grit Grain	Part Number Num produit	Case Caisse	Sleeve Paquet
	2-3/4" x 5" (70 x 125 mm)	040 - 060	6736.4332.xxxx	500	50
		080 - 800	6736.4332.xxxx	600	100
	4-1/2" x 9" (115 x 230 mm)	040 - 060	0439.5603.xxxx	500	50
		080 - 800	0439.5603.xxxx	600	100

Grit / Grain: 40, 60, 80, 100, 120, 150, 180, 220, 240, 280, 320, 400, 500, 600, 800

1950 siaspeed Aluminum Oxide (paper) Corindon (papier)

	Size Dimension	Grit Grain	Part Number Num produit	Case Caisse	Sleeve Paquet
	2-3/4" x 5" (70 x 125 mm)	040 - 060	6783.9190.xxxx	500	50
		080 - 600	6783.9190.xxxx	600	100
		800 - 1500	6783.9190.xxxx	600	100
	2-3/4" x 15-3/4" (70 x 400 mm) 66 holes / trous	040 - 060	9347.4354.xxxx	500	50
		080 - 600	9347.4354.xxxx	600	100
		800 - 1500	9347.4354.xxxx	600	100
	2-3/4" x 16-1/2" (70 x 420 mm)	040 - 060	3210.1376.xxxx	500	50
		080 - 600	3210.1376.xxxx	600	100
		800 - 1500	3210.1376.xxxx	600	100
	3" x 4-3/8" (75 x 110 mm)	040 - 060	1070.7334.xxxx	500	50
		080 - 600	1070.7334.xxxx	500	50
		800 - 1500	1070.7334.xxxx	500	50
	3-1/4" x 5-1/4" (80 x 133 mm) 14 holes / trous	040 - 060	4168.1707.xxxx	500	50
		080 - 600	4168.1707.xxxx	500	50
	4" x 5-3/4" 7 holes / trous Delta	040 - 060	6120.6526.xxxx	900	50
		080 - 400	6120.6526.xxxx	900	50
	4-1/2" x 9" (115 x 230 mm)	040 - 060	0465.4240.xxxx	500	50
		080 - 600	0465.4240.xxxx	600	100
		800 - 1500	0465.4240.xxxx	600	100
	4-1/2" x 9" (115 x 230 mm) 49 holes / trous	040 - 060	4366.8648.xxxx	500	50
		080 - 600	4366.8648.xxxx	600	100
		800 - 1500	4366.8648.xxxx	600	100

Grit / Grain: 40, 60, 80, 100, 120, 150, 180, 220, 240, 280, 320, 400, 500, 600, 800, 1000, 1200, 1500

Film backing for grits from 800 to 1500
Support sur film pour les grains de 800 à 1500



1950 siaspeed



1948 siaflex

siafast Strips - Feuilles coupées siafast





The compact and easy-to-understand range to save time and get a safe process result.

Un système simple et facile à comprendre pour économiser du temps et pour un procédé fiable

1958 siafro	Aluminum Oxide (paper) - Corindon (paper)					
	Size Dimension	No. Holes Nb. trous	Grit Grain	Part Number Numéro de produit	Qty / case Qté / caisse	Qty / sleeve Qté / paquet
	2-3/4" x 15-3/4" 70 x 400 mm	66	100	9515.8032.0100	600	50
		66	200	9515.8032.0200	600	50
		66	300	9515.8032.0300	600	50

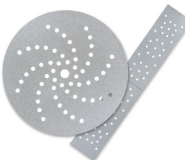
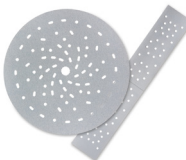
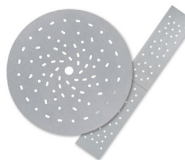
PROductivity - PROductivité	
20 %	Time saving Économie de temps
PROfit - PROfit	
70 %	Less articles to buy Moins d'articles à se procurer
PROefficiency - PROefficacité	
100 %	Safe process results Résultats sûrs à 100%

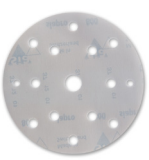

100	200	300	400	800 / 1000	
(80 - 150)	(180 - 240)	(280 - 320)	(360 - 500)	(600 - 1000)	
					
Body fillers - Mastics		Primer fillers - Apprêts		Lacquers - Lacques	
For aggressive cut (Levelling)	For speed (finishing)	For straight cut (levelling)	For high surface quality (finishing)	For scuffing (superfinishing)	
Pour une coupe agressive (planage)	Pour rapidité (finition)	Pour un coupe uniforme (planage)	Pour une surface de qualité (finition)	Pour mattage (superfinition)	

siafro Discs are shown on Page 45

Les disques siafro sont disponibles à la page 45

siafast Sheets (H&L) - Feuilles siafast (auto-agrippant)

1960 siaresx	Aluminum Oxide (paper) Corindon (papier)				
	Size Dimension	Grit Grain	Part Number Num produit	Case Caisse	Sleeve Paquet
	2-3/4" x 5" (70 x 125 mm)	040 - 060	6999.7726.xxxx	500	50
		080 - 600	6999.7726.xxxx	600	100
	3-2/3" x 7-1/2" (93 x 190 mm)	060	1423.2879.0060	500	50
		080 - 400	1423.2879.xxxx	600	100
	3-3/4" x 3-3/4" (95 x 95 mm)	040 - 060	3429.9839.xxxx	500	50
		6 holes / trous	080 - 320	3429.9839.xxxx	600
	4-1/2" x 4-1/2" (115 x 115 mm)	060	8166.0152.0060	500	50
		080 - 400	8166.0152.xxxx	600	100
	4-1/2" x 9" (115 x 230 mm)	040 - 060	0681.2776.xxxx	500	50
		080 - 600	0681.2776.xxxx	600	100





Grit / Grain: 40, 60, 80, 100, 120, 150, 180, 220, 240, 280, 320, 400, 500, 600

7500 sianet CER	Ceramic (screen) C�ramique (treillis)				
	Size Dimension	Grit Grain	Part Number Num produit	Case Caisse	Sleeve Paquet
	2-3/4" x 5" (70 x 125 mm)	080 - 400	7182.0217.xxxx	300	50
	3-1/4" x 5-1/4" (81 x 133 mm)	080 - 400	3479.2740.xxxx	300	50
	3-2/3" x 7" (93 x 180 mm)	080 - 400	7526.3953.xxxx	300	50
	4-1/2" x 9" (115 x 230 mm)	080 - 400	0863.4800.xxxx	300	50

Grit / Grain: 80, 100, 120, 150, 180, 220, 240, 280, 320, 400

7940 siaair	Aluminum oxide (net 3-D) Corindon (treillis 3-D)				
	Size Dimension	Grit Grain	Part Number Num produit	Case Caisse	Sleeve Paquet
	5-1/2" x 4-1/2" (140 x 115 mm)	360 - 4000	6329.7598.xxxx	80	10

Grit / Grain: 360, 500, 600, 800, 1000, 1500, 2000, 4000

7900 sianet	Aluminum Oxide (screen) Corindon (treillis)				
	Size Dimension	Grit Grain	Part Number Num produit	Case Caisse	Sleeve Paquet
	2-3/4" x 5" (70 x 125 mm)	080 - 400	5869.7195.xxxx	300	50
	3-1/4" x 5-1/4" (81 x 133 mm)	080 - 400	2166.9718.xxxx	300	50
	3-2/3" x 7" (93 x 180 mm)	080 - 400	6214.1398.xxxx	300	50
	4-1/2" x 9" (115 x 230 mm)	080 - 400	9519.0126.xxxx	300	50

Grit / Grain: 80, 100, 120, 150, 180, 220, 240, 280, 320, 400



Flexible Hand Sanding Pad
Bloc de pon age flexible

Blocks for siafast Sheets - Blocs pour les feuilles siafast

0020.0342	Dry hand sanding block Bloc de ponçage à sec
	2-3/4" x 5" (70 x 125 mm) siaklett

0020.0343	Dry & wet hand sanding block Bloc à poncer (sec & humide)
	2-3/4" x 5" (70 x 125 mm) mikrolett

016J.4689	Hand sanding glove Mittaine pour ponçage manuel
	2-3/4" x 5" (70 x 125 mm) siaklett

0020.0095	Cork sanding block Bloc en liège
	2-3/4" x 5" (70 x 125 mm) siaklett

0020.6514	Hand sanding block Bloc de ponçage
	2-3/4" x 5" (70 x 125 mm) 29 holes / trous Hard / Dur

0020.6515	Hand sanding block Bloc de ponçage
	2-3/4" x 7-13/16" (70 x 198 mm) 41 holes / trous Hard / Dur

0020.6517	Hand sanding block Bloc de ponçage
	4-1/2" x 9" (115 x 230 mm) 49 holes / trous Hard / Dur

0020.6516	Hand sanding block Bloc de ponçage
	2-3/4" x 15-3/4" (70 x 400 mm) 68 holes / trous Hard / Dur

0020.7045	Flexible Hand Sanding Pad Bloc de ponçage flexible
	2-3/4" x 16-1/2" (70 x 420 mm) 68 holes / trous Hard / Dur

0020.6518	Flexible Hand Sanding Pad Bloc de ponçage flexible
	4-1/2" x 9" (115 x 230 mm) 49 holes / trous Hard / Dur



Series Available in siasoft Sheets disponibles pour les feuilles siasoft

Les séries

Series Série	Grit Range Granulométrie	Type of Grit Type de grain	Type of Backing Type de support	Applications Applications
1901 sialox	150 - 400	Aluminum Ox. Corindon	Paper Papier	Metals, fiberglass, fillers, Métaux, fibre de verre, mastics
1948 siaflex	150 - 800	Aluminum Ox. Corindon	Latex Latex	Metals, fiberglass, fillers, Métaux, fibre de verre, mastics
1950 siaspeed	150 - 1000	Aluminum Ox. Corindon	Paper Papier	Metals, fiberglass, fillers, Métaux, fibre de verre, mastics
2951 siatur h	080 - 220	Aluminum Ox. Corindon	Cloth Toile	Woods (solid, varnished), gypse Bois (solide, vernis), placopâtre

siasoft Sheets (foam backing) - Feuilles siasoft (endos en mousse)

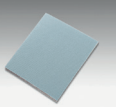
1948 siaflex	Aluminum Oxide (latex) Corindon (latex)				
	Size Dimension	Grit Grain	Part Number Num produit	Case Caisse	Sleeve Paquet
	5-1/2" x 4-1/2" (140 x 115 mm)	150 - 800	4516.5708.xxxx	200	50

Grit / Grain: 150, 180, 220, 240, 280, 320, 400, 500, 600, 800

1901 sialox	Aluminum Oxide (paper) Corindon (papier)				
	Size Dimension	Grit Grain	Part Number Num produit	Case Caisse	Sleeve Paquet
	4" x 6" (100 x 150 mm)	150 - 400	009N.1349.xxx	120	20

Grit / Grain: 150, 180, 220, 320, 400

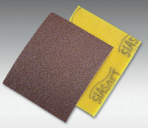
2951 siatur h	Aluminum Oxide (cloth) Corindon (toile)				
	Size Dimension	Grit Grain	Part Number Num produit	Case Caisse	Sleeve Paquet
	5-1/2" x 4-1/2" (140 x 115 mm)	80 - 220	6269.3860.xxxx	120	20

Grit / Grain: 80, 100, 120, 150, 180, 220

1950 siaspeed	Aluminum Oxide (paper) Corindon (papier)				
	Size Dimension	Grit Grain	Part Number Num produit	Case Caisse	Sleeve Paquet
	5-1/2" x 4-1/2" (140 x 115 mm)	150 - 600	4564.0566.xxxx	450	50
		800	4564.0566.0800	450	50
		1000	9947.7255.1000	200	50

Grit / Grain: 150, 180, 220, 240, 280, 320, 400, 500, 600, 800, 1000

Film backing for grits from 800 to 1500
Support sur film pour les grains de 800 à 1500

Non woven Abrasives Abrasifs sur matériel non-tissé



These Hand Pads are shown on page 70
Ces tampons sont disponibles à la page 70

Foam Abrasives Abrasifs sur mousse



These Sponges are shown on Pages 84
Ces éponges sont disponibles aux pages 84

A detailed view of industrial machinery, likely a paper mill or textile loom. A large roll of grey material is mounted on a metal frame. To the right, a vertical panel features several circular gauges and control knobs. The machine is painted in shades of blue and grey. A semi-transparent grey box is overlaid in the center, containing the text 'BELTS' and 'BANDES'.

BELTS
BANDES

Series available for Paper Belts

Les séries disponibles pour les bandes de papier

Series Série	Grit Range Granulométrie	Type of Grit Type de grain	Type of Backing Type de support	Applications Applications
1719 siaral f	180 - 800	Silicon carb. Carb. silicium	E-Paper Papier-E	Varnish Vernis
1749 siaral f	36 - 400	Silicon carb. Carb. silicium	F-Paper Papier-F	MDF, chipboard, composite, varnish MDF, aggloméré, composite, vernis
1909 siawood	60 - 400	Aluminum Ox. Corindon	E-Paper Papier-E	Wood (rabbets & edges) Bois (arêtes & bordures)
1919 siawood	36 - 220	Aluminum Ox. Corindon	F-Paper Papier-F	Wood (rabbets & edges) Bois (arêtes & bordures)

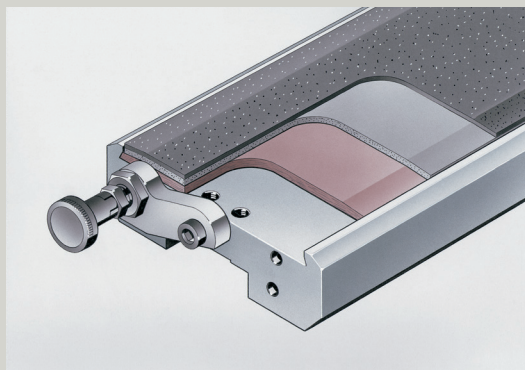

See graphite belts, sanding pads & cushions on pages 30 - 31

Voir les bandes de graphite, patins de ponçage et coussins aux pages 30 - 31

On-site supports by professional Conseils sur place par des professionnels



As requirements become more and more complex, there is an increasing need for specific expertise. Our specialists bring their many years of experience to your door, helping you find optimum solutions to every question involving sanding technology.

Des applications de plus en plus complexes exigent des connaissances de plus en plus spécialisées. Forts de nombreuses années d'expérience, nos spécialistes aident à trouver une solution optimale sur place pour chaque besoin lié au ponçage.

Narrow Belts for Edge Bandes étroites pour champs



Wide Belts larges

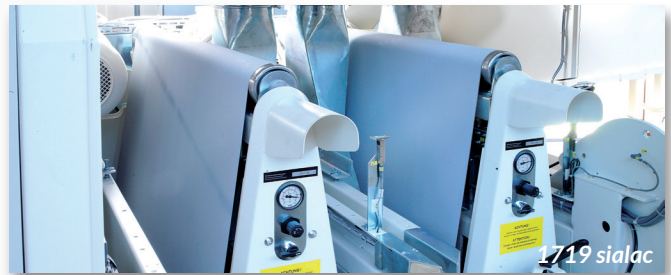

Size Dimension	Séries	Abrasives Abrasifs	Part Number No. produit	Grit Grain	Sleeve Paquet
6" x 108" 150 x 2750 mm	1919 siawood	Alum. Oxide Corindon	8739.0458.xxxx	36 - 220	10
	1719 sialac	Sil. Carbide Carb. silicium	6368.1182.xxxx	180 - 800	10
	1749 siaral f	Sil. carbide Carb. silicium	6345.6862.xxxx	60 - 220	10
6" x 158" 150 x 4020 mm	1919 siawood	Alum. Oxide Corindon	2017.3677.xxxx	36 - 220	10
	1909 siawood	Alum. Oxide Corindon	3211.3994.xxxx	60 - 220	10
	1719 sialac	Sil. Carbide Carb. silicium	3983.8368.xxxx	180 - 800	10
	1749 siaral f	Sil. carbide Carb. silicium	9133.1796.xxxx	60 - 220	10
6" x 264" 150 x 6700 mm	1919 siawood	Alum. Oxide Corindon	4439.0713.xxxx	36 - 220	10
	1719 siaral	Sil. carbide Carb. silicium	2068.1904.xxxx	180 - 220	10
	1749 sialac f	Sil. Carbide Carb. silicium	0748.0314.xxxx	60 - 220	10
1749 siaral f	Grit / Grain: 60, 80, 100, 120, 150, 180, 220, 240, 280, 320, 400				
1719 sialac	Grit / Grain: 180, 220, 240, 260, 280, 320, 400, 500, 600, 800				
1919 siawood	Grit / Grain: 36, 40, 60, 80, 100, 120, 150, 180, 220				
1909 siawood	Grit / Grain: 60, 80, 100, 120, 150, 180, 220, 240, 280, 320, 400				

Other sizes available upon request
Autres dimensions disponibles sur demande

Wide Belts larges

Size Dimension	Séries	Abrasives Abrasifs	Part Number No. produit	Grit Grain	Sleeve Paquet
630 x 1525 mm	1919 siawood	Alum. Oxide Corindon		36 - 220	10
	1719 sialac	Sil. Carbide Carb. silicium		180 - 800	10
630 x 1900 mm	1919 siawood	Alum. Oxide Corindon		36 40 - 60 80 - 220	4 5 10
	1719 sialac	Sil. Carbide Carb. silicium		180 - 800	10
910 x 1525 mm	1919 siawood	Alum. Oxide Corindon		36 - 220	10
	1719 sialac	Sil. Carbide Carb. silicium		180 - 800	10
910 x 1900 mm	1919 siawood	Alum. Oxide Corindon		36 40 - 60 80 - 220	4 5 10
	1719 sialac	Sil. Carbide Carb. silicium		180 - 800	10

Size Dimension	Séries	Abrasives Abrasifs	Part Number No. produit	Grit Grain	Sleeve Paquet
37" x 60" 930 x 1525 mm	1919 siawood	Alum. Oxide Corindon	9562.9761.xxxx	36 - 220	10
	1719 sialac	Sil. Carbide Carb. silicium	7192.0485.xxxx	180 - 800	10
37" x 75" 930 x 1900 mm	1919 siawood	Alum. Oxide Corindon	7703.3262.xxxx	36 40 - 60 80 - 220	4 5 10
	1719 sialac	Sil. Carbide Carb. silicium	5332.3986.xxxx	180 - 800	10
43-3/4" x 75" 1100 x 1900 mm	1919 siawood	Alum. Oxide Corindon	4057.1006.xxxx	36 40 - 60 80 - 220	4 5 10
	1909 siawood	Alum. Oxide Corindon	3041.7440.xxxx	60 80 - 220	5 10
	1719 sialac	Sil. Carbide Carb. silicium	1707.8418.xxxx	180 - 800	10
	1749 siaral f	Sil. carbide Carb. silicium	9555.9679.xxxx	36 40 - 60 80 - 400	4 5 10
51-1/2" x 75" 1310 x 1900 mm	1919 siawood	Alum. Oxide Corindon	7202.1331.xxxx	36 40 - 60 80 - 220	4 5 10
	1719 sialac	Sil. Carbide Carb. silicium	4852.8276.xxxx	180 - 800	10
52" x 103" 1330 x 2620 mm	1919 siawood	Alum. Oxide Corindon	1224.7005.xxxx	36 40 - 60 80 - 220	4 5 10
	1909 siawood	Alum. Oxide Corindon	1008.8936.xxxx	60 80 - 400	5 10
	1719 sialac	Sil. Carbide Carb. silicium	8843.2298.xxxx	180 - 800	10
	1749 siaral f	Sil. carbide Carb. silicium	7523.1175.xxxx	36 - 40 50 - 60 80 - 400	3 5 10
52" x 128" 1330 x 3250 mm	1919 siawood	Alum. Oxide Corindon	4880.3461.xxxx	36 40 - 60 80 - 800	4 5 10
	1719 sialac	Sil. Carbide Carb. silicium	2531.0406.xxxx	180 - 800	10
54" x 75" 1370 x 1900 mm	1919 siawood	Alum. Oxide Corindon	2404.8349.xxxx	36 - 060 80 - 220	5 10
	1719 sialac	Sil. Carbide Carb. silicium	0033.9073.xxxx	180 - 800	10
54" x 84-1/2" 1370 x 2150 mm	1919 siawood	Alum. Oxide Corindon	7810.2448.xxxx	36 - 060 80 - 220	5 10
	1909 siawood	Alum. Oxide Corindon	7594.3912.xxxx	36 - 060 80 - 400	5 10
54" x 103" 1370 x 2620 mm	1919 siawood	Alum. Oxide Corindon	5439.3639.xxxx	180 - 800	10
	1719 sialac	Sil. Carbide Carb. silicium			
54" x 103" 1370 x 2620 mm	1919 siawood	Alum. Oxide Corindon	7994.2898.xxxx	36 - 060 80 - 220	5 10
	1719 sialac	Sil. Carbide Carb. silicium	5645.0310.xxxx	180 - 800	10
64" x 103" 1625 x 2620 mm	1919 siawood	Alum. Oxide Corindon	4497.5722.xxxx	36 - 060 80 - 220	4 10

Other Series Available - Autres séries disponibles

New series for Lacquers - Nouvelles séries pour les vernis



1719 sialac

Silicon carbide, stearate
Carbure de silicium, stéarate

P220 - P800

Water base lacquers
Laques à base aqueuse



1918 sialac

Aluminum Oxide
Oxide d'aluminium

P240 - P600

PU-lacquers, melamine
Laques PE, mélamine



Silicon carbide
Carbure de silicium

P180 - P600

UV-lacquers, melamine
Laques UV, mélamine

Special Order

If a product is not available in our warehouse, we would have the possibility to place a special order in Switzerland. A 4 to 6 week delay is expected.

Commande spéciale

Si un produit n'était pas disponible à notre entrepôt, il nous serait possible de l'importer de Suisse via une commande spéciale. Dans ce cas, il faudra prévoir un délai de 4 à 6 semaines de livraison.

Non Standard Size Paper Belts Grandeur de bandes non standard

Belt's confection core facility

We offer a belt confection service to reach your own needs. This service is available for belts no larger than 12 inches (305 mm).

The confection is rigorously made according to well establish procedures that entirely correspond to the sia abrasives criterias & specifications.

Confection delay is 5 working days. This delay is important to obtain a resistant and strong belt joint.

Service de confection

Nous offrons un service de confection de bandes selon vos propres besoins. Ce service est disponible pour les bandes dont la largeur maximale est de 12 pouces (305 mm).

La confection des bandes se fait selon des procédures établies rigoureusement à notre usine et en accord avec les critères et spécifications de sia abrasives.

Les délais de confection sont de 5 jours ouvrables. Ce délai est nécessaire afin d'obtenir un joint ayant une résistance optimale.

Selection Guide for Cloth Belts

Guide de sélection pour les bandes de toile

Series Série	Grit Range Granulométrie	Type of Grit Type de grain	Type of Backing Type de support	Applications Applications
2511 siabite	36 - 120	Ceram. / alox Céram. / cor.	y-Cloth Toile-y	Metals, stainless steels Métaux, acier inoxydable
2515 siabite	36 - 80	Ceram. / alox Céram. / cor.	y-Cloth Toile-y	Metals, stainless steels Métaux, acier inoxydable
2546 siabite jj	60 - 400	Ceram. / alox Céram. / cor.	jj-Cloth Toile-jj	Metals, stainless steels, curves Métaux, acier inoxydable, courbes
2707 siawat	60 - 180	Silicon carb. Carb. silicium	x-Cloth Toile-x	Granits, glass Granits, verre
2747 siatur	80 - 400	Silicon carb. Carb. silicium	jj-Cloth Toile-jj	Metals, curves & profiles, cultery Métaux, courbes & profil, coutelleries
2800 siaron	24 - 400	Zirc. & alum. Ox. Zirc. & corindon	y-Cloth Toile-y	Metals, aluminum, plastics Métaux, aluminium, plastiques
2812 siaral x	16 - 220	Mixed grains. Grains mélangés	x/y-Cloth Toile-x/y	Wood (cross-grain, glued), veneers Bois (debout, collé) contreplaqué
2820 siamet x	36 - 400	Zirc. & alum. Ox. Zirc. & Corindon	y-Cloth Toile-y	Metals, steels Métaux, aciers
2909 siawood	36 - 320	Aluminum Ox. Corindon	x-Cloth Toile-x	Wood (solid, glues, varnished) Bois (solide, encollé, vernis)
2920 siawood	16 - 220	Aluminum Ox. Corindon	x/y-Cloth Toile-x/y	Wood (solid, glues, varnished) Bois (solide, encollé, vernis)
2925 sialox	24 - 400	Aluminum Ox. Corindon	x-Cloth Toile-x	Ferrous & non ferrous metals, plastics Métaux ferreux, non-ferreux, plastiques
2933 siatur jo	60 - 220	Aluminum Ox. Corindon	jo-Cloth Toile-jo	Resinous woods, curve & profiles Bois tendre et résineux, profils
2936 siatur jj	60 - 320	Aluminum Ox. Corindon	jj-Cloth Toile-jj	Woods, curves & profiles Bois, courbes & profils
2946 siatur jj	60 - 600	Aluminum Ox. Corindon	jj-Cloth Toile-jj	Metals, solid woods, curve & profiles Métaux, bois durs, courbes & profils
2951 siatur h	40 - 600	Aluminum Ox. Corindon	h-Cloth Toile-h	Varnishes, curves & profiles Entre couches de vernis, profils



Nonwoven Belts are Shown on Page 71

Les bandes en matériel non-tissé sont disponibles à la page 71

File Belts & Belts for Drum Sanders Bandes pour limes & ponceuses à "drum"

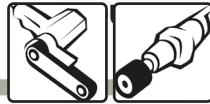

Size Dimension	Serie Série	Abrasive Abrasifs	Grit Grain	Part Number No. produit	Sleeve Paquet
1/2" x 18" 13 x 457 mm	2925 sialox	Al. Oxide Corindon	24 - 400	3714.9438.xxxx	24
	2820 siamet	Zirconia Zirconium	36 - 400	0524.1027.xxxx	24
	2511 siabite	Ceramic Céramique	36 - 120	2917.2391.xxxx	24
1/2" x 24" 13 x 610 mm	2920 siawood	Al. Oxide Corindon	24 - 220	6938.1114.xxxx	24
	2925 sialox	Al. Oxide Corindon	24 - 400	7220.7194.xxxx	24
	2820 siamet	Zirconia Zirconium	36 - 400	3605.2103.xxxx	24
	2511 siabite	Ceramic Céramique	36 - 120	0639.7965.xxxx	24
3/4" x 18" 20 x 457 mm	2920 siawood	Al. Oxide Corindon	24 - 220	4227.3354.xxxx	16
	2925 sialox	Al. Oxide Corindon	24 - 400	5557.1958.xxxx	16
	2820 siamet	Zirconia Zirconium	36 - 400	9834.8246.xxxx	16
	2511 siabite	Ceramic Céramique	36 - 120	5791.1543.xxxx	16
1" x 30" 25 x 760 mm	2920 siawood	Al. Oxide Corindon	24 - 220	2334.4285.xxxx	12
1" x 42" 25 x 1065 mm	2920 siawood	Al. Oxide Corindon	24 - 220	8926.4909.xxxx	10
1-1/2" x 24" 38 x 610 mm	2920 siawood	Al. Oxide Corindon	24 - 220	6931.5791.xxxx	8
	2925 sialox	Al. Oxide Corindon	24 - 400	1457.8459.xxxx	8
	2820 siamet	Zirconia Zirconium	36 - 400	6849.2154.xxxx	8
	2800 siaron	Zirconia Zirconium	24 - 400	8745.2635.xxxx	8
	2511 siabite	Ceramic Céramique	36 - 120	6482.1538.xxxx	8

Other sizes available upon request
Autres dimensions disponibles sur demande

Portable Belts & Narrow Belts Bandes pour ponceuses portatives & bandes étroites



Size Dimension	Serie Série	Abrasive Abrasifs	Grit Grain	Part Number No. produit	Sleeve Paquet
2" x 72" 50 x 1830 mm	2820 siamet	Zirconia Zirconium	36 - 400	6617.3581.xxxx	6
	2511 siabite	Ceramic Céramique	36 - 120	3634.8579.xxxx	6
2-1/2" x 14" 65 x 355 mm	2920 siawood	Al. Oxide Corindon	24 - 220	3433.4298.xxxx	10
2-1/2" x 16" 65 x 410 mm	2920 siawood	Al. Oxide Corindon	24 - 220	1545.0741.xxxx	10
3" x 18" 75 x 457 mm	2920 siawood	Al. Oxide Corindon	24 - 220	1743.4147.xxxx	10
3" x 21" 75 x 533 mm	2920 siawood	Al. Oxide Corindon	24 - 220	3395.6683.xxxx	10
3" x 24" 75 x 610 mm	2920 siawood	Al. Oxide Corindon	24 - 220	5052.5920.xxxx	10
3" x 132" 75 x 3350 mm	2925 sialox	Al. Oxide Corindon	24 - 400	1127.6993.xxxx	4
	2820 siamet	Zirconia Zirconium	36 - 400	2327.4387.xxxx	4
	2511 siabite	Ceramic Céramique	36 - 120	6795.8864.xxxx	4
	2936 siatur jj	Al. Oxide Corindon	60 - 320	8559.3479.xxxx	10
	2946 siatur jj	Al. Oxide Corindon	60 - 600	5060.0926.xxxx	10
4" x 24" 100 x 610 mm	2920 siawood	Al. Oxide Corindon	24 - 220	8037.6118.xxxx	10
2920 siawood	Grit / Grain: 24, 36, 40, 50, 60, 80, 100, 120, 150, 180, 220				
2925 sialox	Grit / Grain: 24, 36, 40, 50, 60, 80, 100, 120, 150, 180, 220, 240, 280, 320, 400				
2800 siaron	Grit / Grain: 24, 36, 40, 50, 60, 80, 100, 120, 150, 180, 240, 320, 400				
2820 siamet	Grit / Grain: 36, 40, 50, 60, 80, 100, 120, 150, 180, 220, 240, 280, 320, 400				
2511 siabite	Grit / Grain: 36, 50, 60, 80, 100, 120				
Flexible backing - Support flexible					
2936 siatur jj	Grit / Grain: 60, 80, 100, 120, 150, 180, 220, 240, 280, 320				
2946 siatur jj	Grit / Grain: 60, 80, 100, 120, 150, 180, 220, 240, 280, 320, 400, 500, 600				

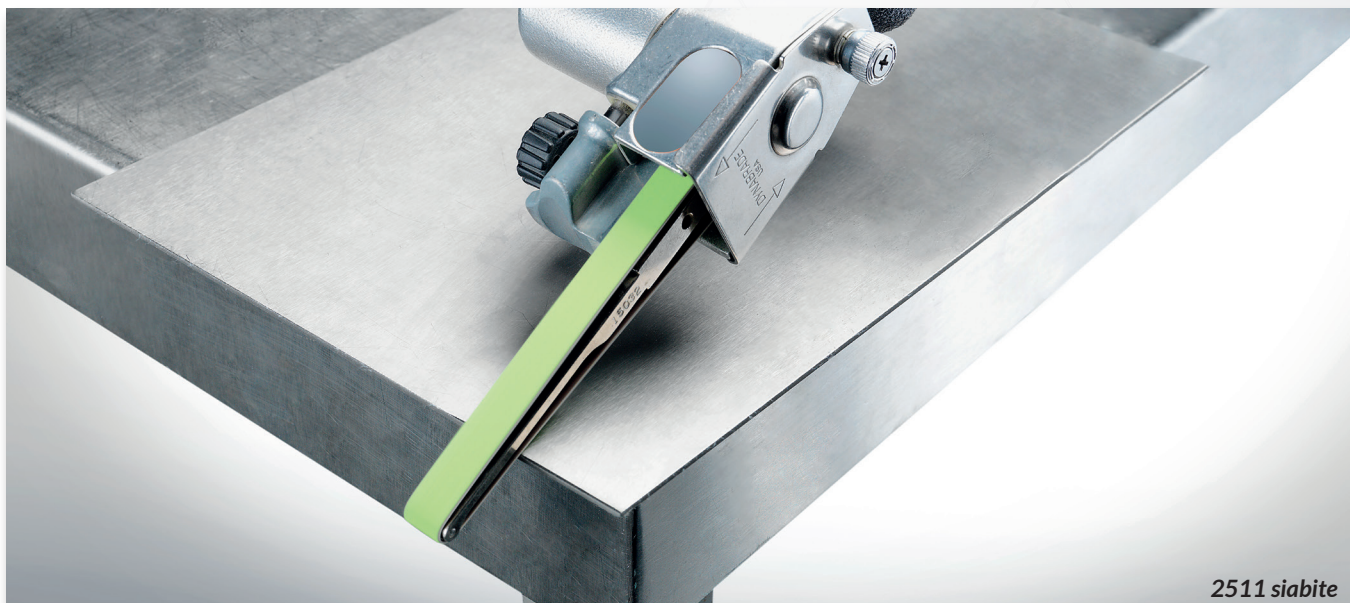

2511 siabite

Narrow Belts Bandes étroites



Size Dimension	Serie Série	Abrasive Abrasifs	Grit Grain	Part Number No. produit	Sleeve Paquet
4" x 36" 100 x 915 mm	2920 siawood	Al. Oxide Corindon	24 - 220	4661.8394.xxxx	10
	2925 sialox	Al. Oxide Corindon	24 - 400	6728.3559.xxxx	3
	2820 siamet	Zirconia Zirconium	36 - 400	2503.3501.xxxx	3
	2511 siabite	Ceramic Céramique	36 - 120	8539.5549.xxxx	3
6" x 48" 150 x 1220 mm	2920 siawood	Al. Oxide Corindon	24 - 220	7256.1066.xxxx	10
6" x 60" 150 x 1525 mm	2920 siawood	Al. Oxide Corindon	24 - 220	3902.0030.xxxx	10
6" x 80" 150 x 2030 mm	2920 siawood	Al. Oxide Corindon	24 - 220	4833.2982.xxxx	10
6" x 89" 150 x 2260 mm	2920 siawood	Al. Oxide Corindon	24 - 220	9820.9746.xxxx	10
6" x 108" 150 x 2740 mm	2920 siawood	Al. Oxide Corindon	24 - 220	0256.9093.xxxx	10
	2925 sialox	Al. Oxide Corindon	24 - 400	0364.8361.xxxx	10
6" x 158" 150 x 4020 mm	2920 siawood	Al. Oxide Corindon	24 - 220	8007.5094.xxxx	2
6" x 202" 150 x 5130 mm	2920 siawood	Al. Oxide Corindon	24 - 220	2099.0897.xxxx	2
6" x 264" 150 x 6700 mm	2920 siawood	Al. Oxide Corindon	24 - 220	6144.4474.xxxx	2
6" x 306" 150 x 7750 mm	2920 siawood	Al. Oxide Corindon	24 - 220	8907.3244.xxxx	2
2920 siawood	Grit / Grain: 24, 36, 40, 50, 60, 80, 100, 120, 150, 180, 220				
2925 sialox	Grit / Grain: 24, 36, 40, 50, 60, 80, 100, 120, 150, 180, 220, 240, 280, 320, 400				
2800 siaron	Grit / Grain: 24, 36, 40, 50, 60, 80, 100, 120, 150, 180, 240, 320, 400				
2820 siamet	Grit / Grain: 36, 40, 50, 60, 80, 100, 120, 150, 180, 220, 240, 280, 320, 400				
2511 siabite	Grit / Grain: 36, 50, 60, 80, 100, 120				

Flexible Belts for Sleeves Bandes flexibles pour ballons



Size Dimension	Serie Série	Abrasive Abrasifs	Grit Grain	Part Number No. produit	Sleeve Paquet
9" x 7-15/32" 230 x 190 mm	2946 siatur jj	Al. Oxide Corindon	60 - 600	6491.3271.xxxx	10
	2933 siatur jo	Al. Oxide Corindon	60 - 220	3233.2914.xxxx	10
9" x 10-39/64" 250 x 272 mm	2946 siatur jj	Al. Oxide Corindon	60 - 600	0824.4837.xxxx	10
	2933 siatur jo	Al. Oxide Corindon	60 - 180	8947.8868.xxxx	10
9" x 13-3/4" 250 x 350 mm	2946 siatur jj	Al. Oxide Corindon	60 - 600	6056.8709.xxxx	10
	2933 siatur jo	Al. Oxide Corindon	60 - 120	0663.3146.xxxx	10
9" x 20" 250 x 510 mm	2946 siatur jj	Al. Oxide Corindon	60 - 600	6914.2253.xxxx	10
	2933 siatur jo	Al. Oxide Corindon	60 - 220	4134.8685.xxxx	10
9" x 26-5/16" 250 x 675 mm	2946 siatur jj	Al. Oxide Corindon	60 - 600	9934.5871.xxxx	10
	2933 siatur jo	Al. Oxide Corindon	60 - 220	7674.6859.xxxx	10
2933 siatur jo	Grit / Grain: 60, 80, 100, 120, 150, 180, 220				
2946 siatur jj	Grit / Grain: 60, 80, 100, 120, 150, 180, 220, 240, 280, 320, 400, 500, 600				

Other sizes available upon request
Autres dimensions disponibles sur demande



2933 siatur jo

Belts for Wood Floor Bandes pour parquet



Wide Belts Bandes Larges



Size Dimension	Serie Série	Abrasive Abrasifs	Grit Grain	Part Number No. produit	Sleeve Paquet
7-7/8" x 29-1/2" 200 x 750 mm	2812 siaral	Al. Oxide Corindon	16 - 36 40 60 - 120	0725.8806.xxxx 0725.8806.0040 0725.8806.xxxx	10 5 10
	2511 siabite	Ceramic Céramique	36 - 120	2214.3791.xxxx	10
	2515 siabite	Ceramic Céramique	36 - 80	4278.6885.xxxx	10
11-7/8" x 29-1/2" 300 x 750 mm	2925 sialox	Al. Oxide Corindon	24 - 400	6124.3627.xxxx	10
	2812 siaral	Al. Oxide Corindon	16, 80, 100 24-40, 120 60	6152.0922.xxxx 2698.1717.xxxx 3081.7733.0060	10
	2820 siamet	Zirconia Zirconium	36 - 400	2866.4928.xxxx	10
	2800 siaron	Zirconia Zirconium	24 - 400	2613.2197.xxxx	10
	2511 siabite	Ceramic Céramique	36 - 120	7124.2139.xxxx	10
	2515 siabite	Ceramic Céramique	36 - 80	6250.9329.xxxx	10
2925 sialox	Grit / Grain: 24, 36, 40, 50, 60, 80, 100, 120, 150, 180, 220, 240, 280, 320, 400				
2800 siaron	Grit / Grain: 24, 36, 40, 50, 60, 80, 100, 120, 150, 180, 240, 320, 400				
2812 siaral	Grit / Grain: 16, 24, 36, 40, 60, 80, 100, 120, 150, 180, 220				
2820 siamet	Grit / Grain: 36, 40, 50, 60, 80, 100, 120, 150, 180, 220, 240, 280, 320, 400				
2511 siabite	Grit / Grain: 36, 50, 60, 80, 100, 120				
2515 siabite	Grit / Grain: 36, 40, 60, 80				

Other sizes available upon request
Autres dimensions disponibles sur demande

Size Dimension	Serie Série	Abrasive Abrasifs	Part Number No. produit	Grit Grain	Sleeve Paquet
25" x 60" 630 x 1525 mm	2920 siawood	Al. Oxide Corindon	5351.4789.xxxx	024	2
				036	3
				040 - 050	4
				060	5
				080 - 120 150 - 220	8 10
25" x 75" 630 x 1900 mm	2920 siawood	Al. Oxide Corindon	3491.8290.xxxx	024	2
				036	3
				040 - 050	4
				060	5
				080 - 120 150 - 220	8 10
36" x 60" 910 x 1525 mm	2920 siawood	Al. Oxide Corindon	2899.6168.xxxx	024	2
				036	3
				040 - 050	4
				060	5
				080 - 220	10
36" x 75" 910 x 1900 mm	2920 siawood	Al. Oxide Corindon	1039.9669.xxxx	024	2
				036	3
				040 - 050	4
				060	5
				080 - 120 150 - 220	8 10
37" x 60" 930 x 1525 mm	2920 siawood	Al. Oxide Corindon	1300.5174.xxxx	024	2
				036	3
				040 - 050	4
				060	5
				080 - 220	10
37" x 75" 930 x 1900 mm	2920 siawood	Al. Oxide Corindon	9408.6556.xxxx	024	2
				036	3
				040 - 050	4
				060	5
				080 - 220	10
43-3/4" x 75" 1100 x 1900 mm	2920 siawood	Al. Oxide Corindon	5762.4767.xxxx	024 - 036	4
				040 - 050	4
				060	5
				080 - 220	10
44" x 103" 1120 x 2620 mm	2920 siawood	Al. Oxide Corindon	8074.2860.xxxx	024 - 036	4
				040 - 050	4
				060	5
				080 - 220	10
52" x 103" 1320 x 2620 mm	2920 siawood	Al. Oxide Corindon	3729.6263.xxxx	024 - 040	3
				050	4
				060 - 080	5
				100 - 120	8
				150 - 220	10
	2925 sialox	Al. Oxide Corindon	3038.0034.xxxx	024 - 040	3
				050	4
				060 - 080	5
				100 - 220	10
2920 siawood	Grit / Grain: 24, 36, 40, 50, 60, 80, 100, 120, 150, 180, 220				
2925 sialox	Grit / Grain: 24, 36, 40, 50, 60, 80, 100, 120, 150, 180, 220, 240, 280, 320, 400				



Non Standard Size Cloth Belts

Grandeur de bandes non standard

Belt confection core facility

We offer a belt confection service to reach your own needs. This service is available for belts no larger than 12 inches (305 mm).

The confection is rigorously made according to well established procedures that entirely correspond to the sia abrasives criteria & specifications.

Several types of joints are available to fulfill your specific applications. Do not hesitate to contact your sales representative for more information.

Production period is 5 working days. This delay is important to obtain a resistant and strong belt joint.



Service de confection

Nous offrons un service de confection de bandes selon vos propres besoins. Ce service est disponible pour les bandes dont la largeur maximale est de 12 pouces (305 mm).

La confection des bandes se fait selon des procédures établies rigoureusement à notre usine et en accord avec les critères et spécifications de sia abrasives.

Plusieurs types de joints sont disponibles selon vos besoins spécifiques. N'hésitez pas à demander conseil auprès de votre représentant.

Le délai de confection est de 5 jours ouvrables. Ce délai est nécessaire afin d'obtenir un joint ayant une résistance optimale.



Available Series - Séries disponibles

Series Série	Grit Grain	Grit size Granulométrie	Series Série	Grit Grain	Grit size Granulométrie
2511 siabite	Ceramic Céramique	36 - 120	2909 siawood	Aluminum Oxide Corindon	60 - 320
2515 siabite y		36 - 080	2920 siawood		24 - 320
2546 siabite jj		60 - 400	2925 sialoX		24 - 400
2707 siawat x	Silicon Carbide Carbure silicium	60 - 180	2933 siatur jo		60 - 220
2747 siatur		80 - 400	2946 siatur jj		80 - 600
2800 siaron	Zirconia Zirconium	24 - 400	2948 siatur jj		80 - 600
2803 siaron y		40 - 180	2951 siatur h		40 - 600
2812 siaral x		16 - 220			
2820 siamet x		36 - 400			
2829 siaron y		24 - 120			

Special Order

If a product is not available in our warehouse, we would have the possibility to place a special order in Switzerland. A waiting period of 8 to 10 week would be expected.

Commande spéciale

Si un produit n'était pas disponible à notre entrepôt, il nous serait possible de l'importer de Suisse via une commande spéciale. Dans ce cas, il faudra prévoir un délai de 8 à 10 semaines de livraison.

Selection Guide for Graphite

Guide de sélection pour le graphite

Series Série	Applications Applications	Properties	Propriétés
HD Heavy duty	For Narrow belts Pour bandes étroites	- Improved durability - More rigid - Construction for tougher jobs	- Durée accrue - Plus rigide - Conçu pour des travaux plus durs
450 Extra HD	For Narrow belts Pour bandes étroites	- Exceptional durability - Recommended for use where extreme conditions are encountered (Température, pression)	- Durée de vie exceptionnelle - Recommandé pour les utilisations extrêmes (température, pression)
303 Flex	For Wide Belts Pour bandes larges	- For polishing and fine finishing	- Pour les étapes de polissage ou de finition
Mitt - Mitaine		- Use for stroke sanding	- Utile pour les ponceuses
Stick - bâton		- Dry lubricant for machines slides - Great belt dressing for the back of sanding belts	- Lubrification des patins - Excellent lubrifiant pour l'endos des bandes à poncer

Canvas Coated with Graphite - Toile de graphite

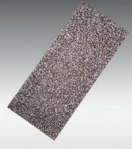
Grade: HD	For Narrow Belts (standard) Pour bandes étroites (régulier)			
Width Largeur	Length Longueur		Part Number Numéro de produit	Sleeve Paquet
	6" (150 mm)	1 yds. 915 mm	GR.HD_610000.0000	1
		25 yds 23 m	GR.HD_625000.0000	1
		50 yds 46 m	GR.HD_650000.0000	1

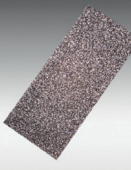
Double coat 450 Double couche	For Narrow Belts (industrial) Pour bandes étroites (industriel)			
Width Largeur	Length Longueur		Part Number Numéro de produit	Sleeve Paquet
	6" (150 mm)	1 yds. 915 mm	GR.450_610000.0000	1
		50 yds 46 m	GR.450_650000.0000	1
	8" (200 mm)	1 yds. 915 mm	GR.450_810000.0000	1
		50 yds 46 m	GR.450_850000.0000	1
	24" (610 mm)	1 yds. 915 mm	GR.450_240100.0000	1
		10 yds 9145 mm	GR.450_241000.0000	1

Flexible Grade 303	For Wide Belts Pour bandes larges			
Width Largeur	Length Longueur		Part Number Numéro de produit	Sleeve Paquet
	6" (150 mm)	1 yds. 915 mm	GR.303_610000.0000	1
		50 yds 46 m	GR.303_650000.0000	1
	8" (200 mm)	1 yds. 915 mm	GR.303_810000.0000	1
		50 yds 46 m	GR.303_850000.0000	1

Other sizes available upon request
Autres dimensions disponibles sur demande

Mitts Mitaines	Side Côté	Part Number Numéro de produit
	Left Gauche	GG.3132L
	Right Droit	GG.3132R

Super slick Bâton	Size Dimension	Part Number Numéro de produit
	2" x 8" (50 x 200 mm)	GG.3134

Cushions for Sanding Pads - Coussins pour patins de ponçage

9063 siafelt	Felt Feutre								
	Thickness Épaisseur	Width Largeur		Length Longueur		Part Number Numéro de produit	Sleeve Paquet		
	1/8" (3 mm)	1-9/16"	40 mm	1 in.	25 mm	FE.9063.112100.0000	1		
				27 yds	25 m	FE.9063.112250.0000	1		
	2"	47 mm	27 yds	25 m	1 in.	25 mm	FE.9063.225000.0000	1	
									27 yds
	2-3/4"	67 mm	27 yds	25 m	1 in.	25 mm	FE.9063.234250.0000	1	
									27 yds
	4-5/16"	110 mm	27 yds	25 m	1 in.	25 mm	FE.9063.412250.0000	1	
									27 yds
	27 / 32" (21 mm)	3-1/8"	80 mm	57 in	1450 mm	57 in	1450 mm	FE.____802000.0000	1
								57 in	1450 mm
Tickness tolerance Tolérance d'épaisseur		1/64" / 10 fts (0,2 mm / 3 m)		Density Densité		0,44 g / cm ³			

9165 siapur	Polyurethane Polyuréthane							
	Thickness Épaisseur	Width Largeur		Length Longueur		Part Number Numéro de produit	Sleeve Paquet	
	7 / 32" (5 mm)	1-9/16"	40 mm	1 in.	25 mm	PU.9165.112100.0000	1	
				27 yds	25 m	0020.0556	1	
	2-3/4"	67 mm	27 yds	25 m	1 in.	25 mm	PU.9165.234100.0000	1
					27 yds	25 m	0020.0557	1
	4-5/16"	110 mm	33 yds	30m	1 in.	25 mm	PU.9165.451610.0000	1
					33 yds	30m	0020.0325	1
Tickness tolerance Tolérance d'épaisseur		1/64" / 10 fts (0,2 mm / 3 m)		Resistance to deformation : up to 120°C Résistance à la déformation : jusqu'à 120°C				

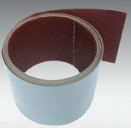
1919 siawood	Antislip Cushions Coussins anti-dérapants						
	Width Largeur		Length Longueur		Grit Grain	Part Number Numéro de produit	Sleeve Paquet
	2-3/4"	70 mm	1 in.	25 mm	60	RA.1919.234100.0060	1
			27 yds	25 m	60	9245.5238.0060	1
	4-5/16"	110 mm	1 in.	25 mm	60	RA.1919.451610.0060	1
			27 yds	25 m	60	0621.0307.0060	1

Chevrons Belts - Bandes à chevrons

Price available upon request
Prix disponible sur demande





ROLLS ROULEAUX

Series Available for Regular Rolls sélection pour les rouleaux standards

Guide de

Series Série	Grit Range Granulométrie	Type of Grit Type de grain	Type of Backing Type de support	Applications Applications
1707 siapar	16 - 36	Silicon carb. Carb. silicium	F-Paper / y-cloth Papier-F / toile-y	Wood (floors) Bois (planchers)
1749 siaral	36 - 400	Silicon carb. Carb. silicium	F-Paper / y-cloth Papier-F / toile-y	Wood (floors) Bois (planchers)
1919 siawood	36 - 220	Aluminum Ox. Corindon	F-Paper Papier-F	Wood (edges & rabbets) Bois (arêtes & bordures)
1960 siarexx	40 - 400	Aluminum Ox. Corindon	C/B-Paper Papier-C/B	Wood (solid, varnished) Bois (solide, vernis)
2915 siarol	40 - 400	Aluminum Ox. Corindon	j-Cloth Toile-j	Polishing metals Polissage des métaux
2920 siawood	24 - 220	Aluminum Ox. Corindon	x/y-Cloth Toile-y/x	Wood (solid, varnished) Bois (solide, vernis)
2933 siatur	60 - 220	Aluminum Ox. Corindon	jo-Cloth Toile-jo	Resinous woods, profiles Bois tendre et résineux, profils
2936 siatur	60 - 320	Aluminum Ox. Corindon	jj-Cloth Toile-jj	Wood, profiles Bois, profils
2946 siatur	60 - 600	Aluminum Ox. Corindon	jj-Cloth Toile-jj	Metals, solid woods, profiles Métaux, bois durs, profils
2951 siatur h	60 - 600	Aluminum Ox. Corindon	h-Cloth Toile-h	Wood (solid, varnished) Bois (solide, vernis)

Accessories for Rolls are Available on Page 38
Les accessoires pour rouleaux sont disponibles à la page 38

Regular Rolls - Rouleaux standards

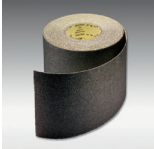
1707 / 1749	Silicon Carbide (paper) Carbure silicium (papier)				
	Size Dimension	Grit Grain	Part Number Num produit	Case Caisse	Sleeve Paquet
	8" x 55 yds (203 mm x 50 m)	040 - 120	6621.1883.xxxx	1	1
	8" x 27 yds (203 mm x 25 m)	016 - 036	4432.6606.xxxx	1	1
	12" x 55 yds (305 mm x 50 m)	040 - 120	5026.9856.xxxx	1	1
	12" x 27 yds (305 mm x 25 m)	016 - 036	0264.3689.xxxx	1	1

Grit / Grain:
1707 siapar: 16, 24, 36
1749 siaral : 40, 50, 60, 80, 100, 120, 120

1960 siarexx	Aluminum Oxide (paper) Corindon (papier)				
	Size Dimension	Grit Grain	Part Number Num produit	Case Caisse	Sleeve Paquet
	3-2/3" x 55 yds (95 mm x 50 m)	060 - 220	4880.2269.xxxx	1	1
	4-1/2" x 55 yds (115 mm x 50 m)	040 - 400	3281.1275.xxxx	1	1

Grit / Grain: 40, 60, 80, 100, 120, 150, 180, 220, 240, 280, 320, 400



Shop Rolls - Rouleaux économiques

2915 siarol	Aluminum Oxide (j-cloth) Corindon (toile-j)				
	Size Dimension	Grit Grain	Part Number Num produit	Case Caisse	Sleeve Paquet
	1" x 55 yds (25 mm x 50 m)	040 - 400	0430.8219.xxxx	1	1
	1-1/2" x 55 yds (38 mm x 50 m)	040 - 400	0388.1861.xxxx	1	1
	2" x 55 yds (50 mm x 50 m)	040 - 400	3415.8417.xxxx	1	1

Grit / Grain: 40, 60, 80, 100, 120, 150, 180, 220, 240, 280, 320, 400



2915 siarol

Regular Rolls - Rouleaux standards

2920 siawood	Aluminum Oxide (x-cloth) Corindon (toile-x)				
	Size Dimension	Grit Grain	Part Number Num produit	Case Caisse	Sleeve Paquet
	4" x 55 yds (100 mm x 50 m)	024 - 320	1924.6535.xxxx	1	1
	6" x 55 yds (150 mm x 50 m)	024 - 320	8187.1992.xxxx	1	1
	12" x 55 yds (305 mm x 50 m)	024 - 036	0069.2541.xxxx	1	1
		040 - 320	0485.5668.xxxx	1	1

Grit / Grain: 24, 36, 40, 50, 60, 80, 100, 120, 150, 180, 220, 280, 320

2936 siatur jj	Aluminum Oxide (JJ-cloth) Corindon (toile-JJ)				
	Size Dimension	Grit Grain	Part Number Num produit	Case Caisse	Sleeve Paquet
	4" x 55 yds (100 mm x 50 m)	060 - 320	0662.2534.xxxx	1	1
	4-1/2" x 55 yds (115 mm x 50 m)	060 - 320	4446.8229.xxxx	1	1

Grit / Grain: 60, 80, 100, 120, 150, 180, 220, 240, 280, 320

2946 siatur jj	Aluminum Oxide (JJ-cloth) Corindon (toile-JJ)				
	Size Dimension	Grit Grain	Part Number Num produit	Case Caisse	Sleeve Paquet
	4" x 55 yds (100 mm x 50 m)	060 - 600	2477.1960.xxxx	1	1
	6" x 55 yds (150 mm x 50 m)	060 - 600	8447.2356.xxxx	1	1
	12" x 55 yds (305 mm x 50 m)	060 - 600	3112.6623.xxxx	1	1

Grit / Grain: 60, 80, 100, 120, 150, 180, 220, 240, 280, 320, 400, 500, 600

2951 siatur h	Aluminum Oxide (h-cloth) Corindon (toile-h)				
	Size Dimension	Grit Grain	Part Number Num produit	Case Caisse	Sleeve Paquet
	4" x 55 yds (100 mm x 50 m)	60 - 600	0986.0338.xxxx	1	1
	6" x 55 yds (150 mm x 50 m)	60 - 600	8555.1624.xxxx	1	1
	12" x 55 yds (305 mm x 50 m)	60 - 600	3112.2714.xxxx	1	1

Grit / Grain: 60, 80, 100, 120, 150, 180, 220, 240, 280, 320, 400, 500, 600

Series Available for siasoft Rolls ponibles pour les rouleaux siasoft

Séries dis-

Series Série	Grit Range Granulométrie	Type of Grit Type de grain	Type of Backing Type de support	Applications Applications
1948 siaflex	120 - 800	Aluminum Ox. Corindon	Latex Latex	Metals, fiberglass, fillers, Métaux, fibre de verre, mastics
1950 siaspeed	150 - 1000	Aluminum Ox. Corindon	Paper / Film Papier / Film	Metals, woods, fiberglass, fillers, Métaux, bois, fibre de verre, mastics
2951 siatur h	80 - 220	Aluminum Ox. Corindon	h-Cloth Toile-h	Woods (solid, varnished) Bois (solide, vernis)

siasoft Rolls (foam backing) - Rouleaux siasoft (endos en mousse)

1948 siaflex	Aluminum Oxide (latex) Corindon (latex)				
	Size Dimension	Grit Grain	Part Number Num produit	Case Caisse	Sleeve Paquet
	4-1/2" x 27 yds (115 mm x 25 m)	120 - 800	2189.9476.xxxx	1	1

Grit / Grain: 120, 150, 180, 220, 240, 280, 320, 400, 500, 600, 800
Roll with 5" pre-cut sheets /
Rouleau avec feuilles pré-coupées à 125 mm

1950 siaspeed	Aluminum Oxide (paper) Corindon (papier)				
	Size Dimension	Grit Grain	Part Number Num produit	Case Caisse	Sleeve Paquet
	4-1/2" x 27 yds (115 mm x 25 m)	150 - 800	2237.4334.xxxx	1	1
		1000	7621.1023.1000	1	1

Grit / Grain: 150, 180, 220, 240, 280, 320, 400, 500, 600, 800, 1000
Roll with 5" pre-cut sheets /
Rouleau avec feuilles pré-coupées à 125 mm

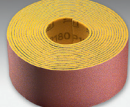
2951 siatur h	Aluminum oxide (h-cloth) Corindon (toile-h)				
	Size Dimension	Grit Grain	Part Number Num produit	Case Caisse	Sleeve Paquet
	3-1/2" x 11 yds (90 mm x 10 m)	080 - 220	3596.0911.xxxx	1	1
	4-1/2" x 11 yds (115 mm x 10 m)	080 - 220	6581.1109.xxxx	1	1

Grit / Grain: 80, 100, 120, 150, 180, 220



2951 siatur h

Series Available for siafast Rolls ponibles pour les rouleaux siafast

Séries dis-

Series Série	Grit Range Granulométrie	Type of Grit Type de grain	Type of Backing Type de support	Applications Applications
1919 siawood	36 - 220	Aluminum Ox. Corindon	F-Paper Papier-F	Wood (edges & rabbets) Bois (arêtes & bordures)
1950 siaspeed	40 - 600	Aluminum Ox. Corindon	Paper Papier	Metals, woods, fiberglass, fillers, Métaux, bois, fibre de verre, mastics
1960 siarexx	40 - 400	Aluminum Ox. Corindon	C/B-Paper Papier-C/B	Woods (solid, varnished) Bois (solide, vernis)
7500 sianet - CER	80 - 400	Ceramic Céramique	Screen Treillis	Wood, Varnish, Gypse Bois, vernis, Placoplâtre
7900 sianet	80 - 400	Aluminum Ox. Corindon	Screen Treillis	Wood, Varnish, Gypse Bois, vernis, Placoplâtre

siafast Rolls - Rouleaux siafast

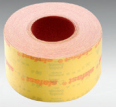
1919 siawood	Aluminum Oxide (paper) Corindon (papier)				
	Size Dimension	Grit Grain	Part Number Num produit	Case Caisse	Sleeve Paquet
	4-1/2" x 27 yds (115 mm x 25 m)	036 - 120 150	3517.8839.xxxx 9316.8917.0150	1 1	1 1
	4" x 55 yds (100 mm x 50 m)	080 - 220	3636.6530.xxxx	1	1

Grit / Grain: 36, 40, 60, 80, 100, 120, 150, 180, 220

1950 siaspeed	Aluminum Oxide (paper) Corindon (papier)				
	Size Dimension	Grit Grain	Part Number Num produit	Case Caisse	Sleeve Paquet
	2-3/4" x 55 yds (70 mm x 50 m)	040 - 600	5096.6824.xxxx	1	1
	Available upon request / Disponible sur demande				
Grit / Grain: 40, 60, 80, 100, 120, 150, 180, 220, 240, 280, 320, 400, 500, 600					

1960 siaresx	Aluminum Oxide (paper) Corindon (papier)				
	Size Dimension	Grit Grain	Part Number Num produit	Case Caisse	Sleeve Paquet
	4-1/2" x 27 yds (115 mm x 25 m)	040 - 400	4415.8289.xxxx	1	1

Grit / Grain: 40, 60, 80, 100, 120, 150, 180, 220, 240, 320, 400

7500 sianet CER	Ceramic (screen) C�ramique (treillis)				
	Size Dimension	Grit Grain	Part Number Num produit	Case Caisse	Sleeve Paquet
	4-1/2" x 11 yds (115 mm x 10 m)	080 - 400	2969.2150.xxxx	1	1

Grit / Grain: 80, 100, 120, 150, 180, 220, 240, 320, 400

7900 sianet	Aluminum Oxide (screen) Corindon (treillis)				
	Size Dimension	Grit Grain	Part Number Num produit	Case Caisse	Sleeve Paquet
	4-1/2" x 11 yds (115 mm x 10 m)	080 - 400	1635.2907.xxxx	1	1

Grit / Grain: 80, 100, 120, 150, 180, 220, 240, 320, 400



Self adhesive Rolls - Rouleaux auto-collants

1950 siaspeed	Aluminum Oxide (paper) Corindon (papier)				
	Size Dimension	Grit Grain	Part Number Num produit	Case Caisse	Sleeve Paquet
	2-3/4" x 25 yds (70 mm x 23 m)	040 - 500	5014.2229.xxxx	1	1
	4-1/2" x 10 yds (115 mm x 9 m)	100 - 600	3752.5933.xxxx	1	1

Grit / Grain: 40, 60, 80, 100, 120, 150, 180, 220, 240, 280, 320, 400, 500, 600

Rolls (Other sizes) - Rouleaux (Autres dimensions)

A wide selection of rolls are available upon request

To order, you have to select:

- Length: 27 or 55 yds (25 or 50 M)
- Width: 1/2" to 52" (13 to 1320 mm)
- Series & Grit:

Une grande variété de rouleaux sont disponibles sur demande

Pour commander, choisissez la:

- Longueur: 27 or 55 yds (25 ou 50 M)
- Largeur: 1/2" to 52" (13 à 1320 mm)
- Série et grain:

Available Series - Séries disponibles

Paper Rolls Rouleaux de papier

Cloth Rolls Rouleaux de toile

Series Série	Grit Grain	Grit size Granulométrie	Series Série	Grit Grain	Grit size Granulométrie
			2511 siabite	Ceramic Céramique	036 - 120
1749 siaral F	Silicon Carbide Carbure silicium	036 - 400	2707 siawat	Silicon Carbide Carbure silicium	060 - 180
1820 siamet F	Zirconia Zirconium	040 - 400	2800 siaron 2803 siaron 2812 siaral x 2820 siamet x	Zirconia Zirconium	024 - 400 036 - 180 016 - 220 036 - 400
1909 siawood 1919 siawood 1920 siawood	Aluminum Oxide Corindon	060 - 400 036 - 220 060 - 400	2909 siawood 2920 siawood 2925 sialox	Aluminum Oxide Corindon	060 - 320 016 - 220 024 - 400
			2906 siatur j 2933 siatur jo 2936 siatur jj 2946 siatur h 2948 siatur jj	Alum. Ox.(flexible) Corindon (flexible)	060 - 320 060 - 220 060 - 320 060 - 600 040 - 600

511M.7118	Hand sanding file (siafast) Râpe de ponçage
	4-1/2" x 31" (120 x 800 mm) no holes sans trous Hard / dur



Hand sanding file
Râpe de ponçage

Other Abrasives

Autres abrasifs



Nonwoven Abrasives
Abrasifs sur matériel non-tissé

These Rolls are shown on Page 72
Ces rouleaux sont disponibles à la page 72

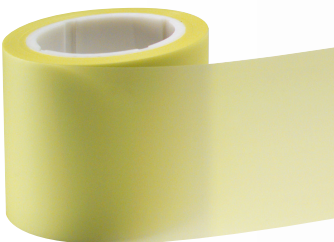

Micro & Super Abrasives
Micro & super abrasifs

Information about these Rolls are shown on Pages 87 - 92
Information disponibles aux pages 87 - 92



**DISCS
DISQUES**

Series Available in Self Adhesive Discs

Séries disponibles pour les disques autocollants

Series Série	Grit Range Granulométrie	Type of Grit Type de grain	Type of Backing Type de support	Applications Applications
1815 siatop	020 - 400	Zirconia Zirconium	Fibre / Paper Fibre / Papier	Metals, composites Métaux, composites
1919 siawood	040 - 220	Aluminum Ox. Corindon	F-Paper Papier-F	Woods, non-ferrous metals Bois, métaux non-ferreux
1948 siaflex	080 - 600	Aluminum Ox. Corindon	Latex Latex	Composites, fillers, aluminum, steel Composites, mastics, aluminium, aciers
1950 siaspeed	040 - 600	Aluminum Ox. Corindon	Paper / Film Papier / Film	Metals, fiberglass, fillers Métaux, fibre de verre, mastics
2920 siawood	024 - 220	Aluminum Ox. Corindon	x/y-Cloth Toile-x/y	Wood (solid, glues, varnished) Bois (solide, encollé, vernis)
2951 siatur h	080 - 220	Aluminum Ox. Corindon	h-Cloth Toile-h	Varnishes, curves & profiles Entre les couches vernis, profils

Accessories for Self-Adhesive Discs (PSA) are shown on Page 41
Les accessoires pour les disques autocollants sont disponibles à la page 41

Self Adhesive Discs - Disques autocollants

Zirconia (fibre / paper) Zirconium (fibre / papier)					
	Size Dimension	Grit Grain	Part Number Num produit	Case Caisse	Sleeve Paquet
	5" (125 mm)	024 - 400		400	100
	6" (150 mm)	024 - 400		400	100

Grit / Grain: 24, 36, 40, 50, 60, 80, 100, 120, 150, 180, 220, 240, 280, 320, 400

1948 siaflex					
Aluminum Oxide (latex) Corindon (latex)					
	Size Dimension	Grit Grain	Part Number Num produit	Case Caisse	Sleeve Paquet
	5" (125 mm)	080 - 600	5659.4836.xxxx	400	100
	6" (150 mm)	080 - 600	6208.6781.xxxx	400	100

Grit / Grain: 80, 100, 120, 150, 180, 220, 320, 400, 600

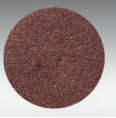
1919 siawood					
Aluminum Oxide (paper) Corindon (papier)					
	Size Dimension	Grit Grain	Part Number Num produit	Case Caisse	Sleeve Paquet
	6" (150 mm)	040 - 220	2197.5101.xxxx	25	1
	8" (205 mm)	040 - 220	3384.1159.xxxx	25	1
	9" (230 mm)	040 - 220	3933.3104.xxxx	25	1
	10" (250 mm)	040 - 220	4372.6660.xxxx	25	1
	12" (305 mm)	040 - 220	5559.2718.xxxx	25	1
	16" (407 mm)	040 - 220	7765.3900.xxxx	25	1
	20" (510 mm)	040 - 220	9997.8004.xxxx	25	1
	24" (610 mm)	040 - 220	2183.4994.xxxx	25	1

Grit / Grain: 40, 60, 80, 100, 120, 150, 180, 220

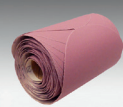
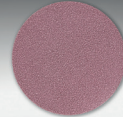
1950 siaspeed					
Aluminum Oxide (paper) Corindon (papier)					
	Size Dimension	Grit Grain	Part Number Num produit	Case Caisse	Sleeve Paquet
	5" (125 mm)	040 - 600	5706.9694.xxxx	400	100
	6" (150 mm)	040 - 600	6256.1639.xxxx	400	100
	5" (125 mm)	040 - 600	8777.2883.xxxx	400	100
	6" (150 mm)	040 - 600	9326.4828.xxxx	400	100

Grit / Grain: 40, 60, 80, 100, 120, 150, 180, 220, 240, 280, 320, 400, 500, 600

Self Adhesive Discs - Disques autocollants

2920 siawood	Aluminum Oxide (cloth) Corindon (toile)				
	Size Dimension	Grit Grain	Part Number Num produit	Case Caisse	Sleeve Paquet
	6" (150 mm)	024 - 220	5870.5126.xxxx	25	1
	9" (230 mm)	024 - 220	7606.3129.xxxx	25	1
	12" (305 mm)	024 - 220	9232.2743.xxxx	25	1
	16" (407 mm)	024 - 220	1470.6044.xxxx	25	1
	20" (510 mm)	024 - 220	3703.0148.xxxx	25	1

Grit / Grain: 24, 36, 40, 60, 80, 120, 220

2951 siatur h	Aluminum Oxide (cloth) Corindon (toile)				
	Size Dimension	Grit Grain	Part Number Num produit	Case Caisse	Sleeve Paquet
	5" (125 mm)	080 - 220	0514.8296.xxxx	500	50
	6" (150 mm)	080 - 220	1064.0241.xxxx	500	50

Grit / Grain: 80, 100, 120, 150, 180, 220

Accessories for Self Adhesive Discs Accessoires pour disques autocollants

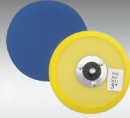
5" (125 mm)	Pads Plateaux (5/16")	
	Hardness Dureté	Part Number Numéro de produit
	Soft Mou	0020.6732
	Medium Moyen	003F.0125
	Hard Dur	0020.6733

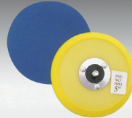
6" (150 mm)	Pads Plateaux (5/16")	
	Hardness Dureté	Part Number Numéro de produit
	Soft Mou	0020.6738
	Medium Moyen	004F.9163
	Hard Dur	0020.6739

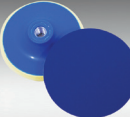
5" (125 mm)	Pads for 1815 siamet Plateaux pour le 1820 siamet (5/8"-11)	
	Hardness Dureté	Part Number Numéro de produit
	Hard Dur	062F.7558

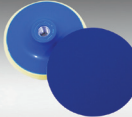
6" (150 mm)	Pads for 1815 siamet Plateaux pour le 1820 siamet (5/8"-11)	
	Hardness Dureté	Part Number Numéro de produit
	Hard Dur	132F.0019

Series Available siafast discs lection pour disques siafast

Guide de sé-

Series Série	Grit Range Granulométrie	Type of Grit Type de grain	Type of Backing Type de support	Applications Applications
1707 siapar	016 - 036	Silicon carb. Carb. silicium	F-Paper / y-cloth Papier-F / toile-y	Concrete, wood (solid, varnished) Ciment, bois (massif, vernis)
1749 siaral	040 - 150	Silicon carb. Carb. silicium	F-Paper / y-cloth Papier-F / toile-y	Concrete, wood (solid, varnished) Ciment, bois (massif, vernis)
1815 siatop	024 - 120	Zirc. & Alum. Ox Zirc. & Corindon	Paper & carbon fiber Papier & fibre carbone	Steel, stainless steel, aluminum Acier, acier inoxydable, aluminium
1913 siawat fc	800 - 2500	Aluminum Ox. Corindon	C/D-Paper Papier-C/D	Composites, body shop, water proof Composites, carrosserie, imperméable
1919 siawood	040 - 220	Aluminum Ox. Corindon	F-Paper Papier-F	Woods, non-ferrous metals Bois, métaux non-ferreux
1944 siaone	040 - 500	Aluminum Ox. Corindon	C/B-Paper Papier-C/B	Fillers, primers, old lacquers Mastic, apprêts, old lacques
1948 siaflex	040 - 800	Aluminum Ox. Corindon	Latex Latex	Composites, fillers, aluminum, steel Composites, mastics, aluminium, aciers
1958 siaPRO	100 - 1000	Mixed grits Grains mélangés	Paper, flim (dry) Papier, film (à sec)	Fillers, primers, lacquers Mastic, apprêts, lacques
1950 siaspeed	040 - 1500	Aluminum Ox. Corindon	Paper / film Papier / film	Metals, fiberglass, fillers Métaux, fibre de verre, mastics
1960 siarexx	040 - 600	Aluminum Ox. Corindon	C/B-Paper Papier-C/B	Woods (solid, varnished) Bois (solide, vernis)
2546 siabite jj	060 - 240	Ceramic & Alum. Ox Céramique & corindon	jj-Cloth Toile-jj	High alloy steels Aciers hautement alliés
2920 siawood	024 - 180	Aluminum Ox. Corindon	x/y-Cloth Toile-x/y	Wood (solid, glues, varnished) Bois (solide, encollé, vernis)
7240 siacarat	500 - 3000	Diamond Diamant	3-D net Réticulé	Scratch resistant surfaces Surfaces résistantes aux égratignures
7241 carbon	080 - 500	Diamond Diamant	3-D net Réticulé	Stone, concrete, ceramics, fiberglass Pierre, ciment, céramique, fibre de verre
7500 sianet CER	080 - 400	Ceramic Céramique	Screen Treilli	Aerospace, wood, varnish, gypse Aéronautique, bois, vernis, placoplâtre
7900 sianet	080 - 400	Aluminum Ox. Corindon	Screen Treilli	Wood, varnish, gypse Bois, vernis, Placoplâtre
7940 siaair	240 - 4000	Aluminum Ox. Corindon	3-D net Réticulé	bodyshop, woods Carrosserie, bois

Accessories for siafast Discs are shown on Pages 48 - 53
Les accessoires pour les disques siafast sont disponibles aux pages 48 - 53



1948 siaflex



siafast Discs - Disques siafast

Silicone Carbide (paper) Carbure silicium (papier)					
	Size Dimension	Grit Grain	Part Number Num produit	Case Caisse	Sleeve Paquet
	6" (150 mm)	016 - 036		250	25
		040 - 150		500	50

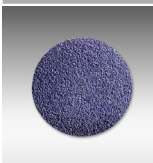
: 16, 24, 36
:40, 50, 60, 80, 100, 120, 150

1815 siatop					
Zirconia (fibre / paper) Zirconium (fibre / papier)					
	Size Dimension	Grit Grain	Part Number Num produit	Case Caisse	Sleeve Paquet
	4-1/2" (115 mm)	024 - 120	3650.1158.xxxx	500	50
	5" (125 mm)	024 - 120	3869.7936.xxxx	500	50
	6" (150 mm)	024 - 120	4418.9881.xxxx	500	50
	7" (180 mm)	024 - 120	5056.3994.xxxx	500	50

Grit / Grain: 24, 36, 40, 50, 60, 80, 100, 120

1913 siawat fc					
Aluminum Oxide (paper) Corindon (papier)					
	Size Dimension	Grit Grain	Part Number Num produit	Case Caisse	Sleeve Paquet
	1-3/8" (37 mm)	1000 - 2500	4269.7970.xxxx	500	100
		1500 - 2500	5013.8691.xxxx	500	100
	3" (80 mm)	1500 - 2500	5013.8691.xxxx	500	100
	6" (150 mm)	0800 - 2500	6529.9916.xxxx	500	100

Grit / Grain: 800, 1000, 1200, 1500, 2000, 2500

1948 siaflex					
Aluminum Oxide (latex) Corindon (latex)					
	Size Dimension	Grit Grain	Part Number Num produit	Case Caisse	Sleeve Paquet
	5" (125 mm)	040 - 060	6736.2380.xxxx	500	50
		080 - 600	6736.2380.xxxx	600	100
		800	6736.2380.0800	300	50
	5" (125 mm) 5 holes / trous	040 - 060	0798.0972.xxxx	500	50
		080 - 600	0798.0972.xxxx	600	100
		800	0798.0972.0800	300	50
	5" (125 mm) 8 holes / trous	040 - 060	8239.3460.xxxx	500	50
		080 - 600	8239.3460.xxxx	600	100
		800	8239.3460.0800	300	50
	5" (125 mm) 41 holes / trous	040 - 060	7111.8012.xxxx	500	50
		080 - 600	7111.8012.xxxx	600	100
		800	7111.8012.0800	300	50
	6" (150 mm)	040 - 060	7285.4325.xxxx	500	50
		080 - 600	7285.4325.xxxx	600	100
		800	7285.4325.0800	300	50
	6" (150 mm) 7 holes / trous	040 - 600	8390.6852.xxxx	500	50
		080 - 600	8390.6852.xxxx	600	100
		800	8390.6852.0800	300	50
	6" (150 mm) 15 holes / trous	040 - 060	7498.8090.xxxx	500	50
		080 - 600	7498.8090.xxxx	600	100
		800	7498.8090.0800	300	50
	6" (150 mm) 57 holes / trous	040 - 60	1520.4046.xxxx	500	50
		080 - 600	1520.4046.xxxx	600	100
		800	1520.4046.0800	300	50

Grit / Grain: 40, 60, 80, 100, 120, 150, 180, 220, 240, 280, 320, 400, 500, 600, 800

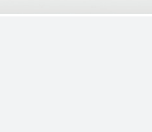
1919 siawood					
Aluminum Oxide (paper) Corindon (papier)					
	Size Dimension	Grit Grain	Part Number Num produit	Case Caisse	Sleeve Paquet
	5" (125 mm)	040 - 220	6123.2545.xxxx	500	50
	6" (150 mm)	040 - 220	6650.8269.xxxx	500	50
	7" (180 mm)	040 - 220	7309.8603.xxxx	500	1
	8" (200 mm)	040 - 220	7749.2159.xxxx	500	1
	9" (230 mm)	040 - 220	8386.6272.xxxx	500	1
	12" (305 mm)	040 - 220	0044.8005.xxxx	500	1
	16" (407 mm)	040 - 220	2250.9187.xxxx	25	1

Grit / Grain: 40, 60, 80, 100, 120, 150, 180, 220

siafast Discs - Disques siafast

▶ Initial aggressive cut



▶ Process stability

▶ Affordable price

▶ Coupe initiale agressive

▶ Stabilité du procédé grâce à une profondeur de rugosité cohérente

▶ Bon rapport prix / performance

1944 siaone	Aluminum Oxide (paper) - Corindon (paper)				
	Size Dimension	Grit Grain	Part Number Numéro de produit	Qty / case Qté / caisse	Qty / sleeve Qté / paquet
	5" (125 mm)	040 - 60	6662.8885.xxxx	500	50
		080 - 500	6662.8885.xxxx	600	50
	6" (150 mm)	040 - 100	7190.4609.xxxx	500	50
		120 - 500	7190.4609.xxxx	700	50

Grit / Grain: 40, 60, 80, 100, 120, 150, 180, 220, 240, 320, 400, 500



1944 siaone

siafast Discs - Disques siafast

1958 siapro	Aluminum Oxide - Corindon					
	Size Dimension	No. Holes Nb. trous	Grit Grain	Part Number Numéro de produit	Qty / case Qté / caisse	Qty / sleeve Qté / paquet
	6" (150 mm)	57	100	1736.2582.0100	600	100
		81	200	8633.7741.0200	600	100
		81	300	8633.7741.0300	600	100
		81	400	8633.7741.0400	600	100
		15	800	7714.6626.0800	300	50
		W/O - sans	1000	5404.1437.1000	20	5

PROductivity - PROductivité	
20 %	Time saving Économie de temps
PROfit - PROfit	
70 %	Less articles to buy Moins d'articles à se procurer
PROefficiency - PROefficacité	
100 %	Safe process results Résultats sûrs à 100%



100	200	300	400	800 / 1000	
(80 - 150)	(180 - 240)	(280 - 320)	(360 - 500)	(600 - 1000)	
Body fillers - Mastics		Primer fillers - Apprêts		Lacquers - Lacques	
For aggressive cut (Levelling)	For speed (finishing)	For straight cut (levelling)	For high surface quality (finishing)	For scuffing (superfinishing)	
Pour une coupe agressive (planage)	Pour rapidité (finition)	Pour un coupe uniforme (planage)	Pour une surface de qualité (finition)	Pour mattage (superfinition)	

siapro Strips are shown on Page 17
Les feuilles coupées siapro sont disponibles à la page 17

siafast Discs - Disques siafast

1950 siaspeed	Aluminum Oxide (paper) Corindon (papier)				
	Size Dimension	Grit Grain	Part Number Num produit	Case Caisse	Sleeve Paquet
	3" (80 mm)	040 - 60	5816.8425.xxxx	500	50
		080 - 600	5816.8425.xxxx	500	50
		800 - 1500	5816.8425.xxxx	500	50
	3" (77 mm) 6 holes / trous	040 - 60	1270.8925.xxxx	500	50
		080 - 600	1270.8925.xxxx	500	50
		800 - 1500	1270.8925.xxxx	500	50
	3-1/2" (90 mm) 7 holes / trous	040 - 60	1236.7347.xxxx	600	100
		080 - 600	1236.7347.xxxx	600	100
	4-1/2" (115 mm)	040 - 60	6564.0927.xxxx	600	100
		080 - 600	1236.7347.xxxx	600	100
	5" (125 mm)	040 - 60	6783.7705.xxxx	500	50
		080 - 600	6783.7705.xxxx	600	100
		800 - 1500	6783.7705.xxxx	300	50
	5" (125 mm) 5 holes / trous	040 - 60	0845.6297.xxxx	500	50
		080 - 600	0845.6297.xxxx	600	100
		800 - 1500	0845.6297.xxxx	300	50
	5" (125 mm) 8 holes / trous	040 - 60	8286.8318.xxxx	500	50
		080 - 600	8286.8318.xxxx	600	100
		800 - 1500	8286.8318.xxxx	300	50
	5" (125 mm) 65 holes / trous	100 - 600	4089.0148.xxxx	600	100
	5" (125 mm) 41 holes / trous	040	7159.2870.0040	500	50
		060	7159.2870.0060	500	50
		080	7159.2870.0080	600	100
	5" (125 mm) 9 holes / trous (Festool)	040 - 060	3886.3796.xxxx	500	50
		080 - 400	3886.3796.xxxx	600	100

Grit / Grain: 40, 60, 80, 100, 120, 150, 180, 220, 240, 280, 320, 400, 500, 600, 800, 1000, 1200, 1500

Film backing for grits from 800 to 1500
Support sur film pour les grains de 800 à 1500

1950 siaspeed	Aluminum Oxide (paper) Corindon (papier)				
	Size Dimension	Grit Grain	Part Number Num produit	Case Caisse	Sleeve Paquet
	6" (150 mm)	040 - 60	7332.9183.xxxx	500	50
		080 - 600	7332.9183.xxxx	600	100
		800 - 1500	7332.9183.xxxx	300	50
	6" (150 mm) 7 holes / trous	040 - 60	8438.1710.xxxx	500	50
		080 - 600	8438.1710.xxxx	600	100
		800 - 1500	8438.1710.xxxx	300	50
	6" (150 mm) 15 holes / trous	040 - 60	7546.2948.xxxx	500	50
		080 - 600	7546.2948.xxxx	600	100
		800 - 1500	7546.2948.xxxx	300	50
	6" (150 mm) 81 holes / trous	100 - 600	8443.7842.xxxx	600	100
	6" (150 mm) 57 holes / trous	040	1546.3150.0040	500	50
		060	1546.3150.0060	500	50
		080	1546.3150.0080	600	100
	6" (150 mm) 49 holes / trous (Festool)	040 - 060	3817.0427.xxxx	500	50
		080 - 600	3817.0427.xxxx	600	100
	8" (203 mm)	040 - 60	8466.9397.xxxx	500	50
		080 - 600	8466.9397.xxxx	600	100
		800 - 1500	8466.9397.xxxx	300	50
	8" (203 mm) 9 holes / trous	040 - 60	5002.6471.xxxx	500	50
		080 - 600	5002.6471.xxxx	500	50
		800 - 1000	5002.6471.xxxx	300	50





Grit / Grain: 40, 60, 80, 100, 120, 150, 180, 220, 240, 280, 320, 400, 500, 600, 800, 1000, 1200, 1500

Film backing for grits from 800 to 1500
Support sur film pour les grains de 800 à 1500

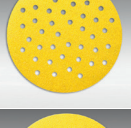

1950 siaspeed

siafast Discs - Disques siafast

1960 siaorex	Aluminum Oxide (paper) Corindon (papier)				
	Size Dimension	Grit Grain	Part Number Num produit	Case Caisse	Sleeve Paquet
	5" (125 mm)	040 - 060	6999.5774.xxxx	500	50
		080 - 600	6999.5774.xxxx	600	100
	5" (125 mm) 5 holes / 5 trous	040 - 060	1061.4366.xxxx	500	50
		080 - 600	1061.4366.xxxx	600	100
	5" (125 mm) 8 holes / trous	040 - 060	8502.6854.xxxx	500	50
		080 - 600	8502.6854.xxxx	600	100
	5" (125 mm) 41 holes / trous	040 - 080	5016.4703.xxxx	500	50
		100 - 180	5730.7754.xxxx	600	100
		220 - 600	5016.4703.xxxx	600	100
	6" (150 mm)	040 - 060	7548.7719.xxxx	500	50
		080 - 600	7548.7719.xxxx	600	100
	6" (150 mm) 7 holes / trous	040 - 060	8654.0246.xxxx	500	50
		080 - 600	8654.0246.xxxx	600	100
	6" (150 mm) 57 holes / trous	040 - 080	1762.1219.xxxx	500	50
		100 - 180	1762.1219.xxxx	600	100
		220 - 600	1762.1219.xxxx	600	100
	8-11/16" (220 mm)	080	9064.8944.0080	500	50
		100 - 180	9064.8944.xxxx	500	100
		220	9064.8944.0220	500	50
	9" (225 mm) 18 + 1 holes / trous Festool	080 - 240	2234.7823.xxxx	100	25

Grit / Grain: 40, 60, 80, 100, 120, 150, 180, 220, 240, 280, 320, 400, 500, 600

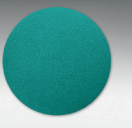
2546 siabite jj	Ceramic (cloth) C�ramique (toile)				
	Size Dimension	Grit Grain	Part Number Num produit	Case Caisse	Sleeve Paquet
	4-1/2" (115 mm)	060 - 240	9495.3729.xxxx	600	50
	5" (125 mm)	060	9715.0507.0060	500	50
		080 - 240	9715.0507.xxxx	600	50
	6" (150 mm)	060	0274.8350.0060	500	50
		080 - 240	0274.8350.xxxx	600	50

Grit / Grain: 60, 80, 120, 180, 240

2920 siawood	Aluminum Oxide (cloth) Corindon (toile)				
	Size Dimension	Grit Grain	Part Number Num produit	Case Caisse	Sleeve Paquet
	2" (50 mm)	024 - 120	6202.6692.xxxx	500	100
	3" (75 mm)	024 - 120	6751.8637.xxxx	500	100
	4-1/2" (115 mm)	024 - 120	7608.9528.xxxx	500	100
		024 - 120	7828.6306.xxxx	500	100
		024 - 120	8377.8251.xxxx	500	100
		024 - 120	9015.2364.xxxx	500	100
		024 - 120	9015.2364.xxxx	500	100

Grit / Grain: 24, 36, 40, 60, 80, 120



1960 siaorex

siafast Discs - Disques siafast

7240 siacarat	Diamond (3-D foam) Diamant (mousse 3-D)				
	Size Dimension	Grit Grain	Part Number Num produit	Case Caisse	Sleeve Paquet
	3" (80 mm)	500 - 3000	8451.8686.xxxx	40	4
	6" (150 mm)	500 - 3000	9967.9911.xxxx	20	2

Grit / Grain: 500, 1000, 2000, 3000

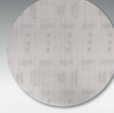
7500 sianet CER	Ceramic (screen) C�ramique (treillis)				
	Size Dimension	Grit Grain	Part Number Num produit	Case Caisse	Sleeve Paquet
	3" (80 mm)	080 - 400	6214.8985.xxxx	500	50
	5" (125 mm)	080 - 400	7181.8265.xxxx	300	50
	6" (150 mm)	080 - 400	7709.3989.xxxx	300	50
	8-11/16" (220 mm)	080 - 220	9335.3603.xxxx	100	25

Grit / Grain: 80, 100, 120, 150, 180, 220, 240, 320, 400

7241 siacarbon	Diamond (3-D foam) Diamant (mousse 3-D)				
	Size Dimension	Grit Grain	Part Number Num produit	Case Caisse	Sleeve Paquet
	3" (80 mm)	080 - 500	8486.4459.xxxx	80	20
	5" (125 mm)	080 - 500	9453.3739.xxxx	40	10
	6" (150 mm)	080 - 500	9980.9463.xxxx	40	10

Grit / Grain: 80, 120, 180, 240, 320, 500

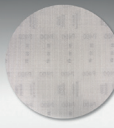
7900 sianet	Aluminum Oxide (screen) Corindon (treillis)				
	Size Dimension	Grit Grain	Part Number Num produit	Case Caisse	Sleeve Paquet
	3" (80 mm)	080 - 400	4881.0209.xxxx	500	50
	5" (125 mm)	080 - 400	5869.5710.xxxx	300	50
	6" (150 mm)	080 - 400	6397.0967.xxxx	300	50
	8-11/16" (220 mm)	080 - 220	8023.0581.xxxx	100	25

Grit / Grain: 80, 100, 120, 150, 180, 220, 240, 320, 400

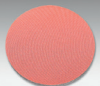
7940 siaair	Aluminum Oxide (3-D foam) Corindon (mousse 3-D)				
	Size Dimension	Grit Grain	Part Number Num produit	Case Caisse	Sleeve Paquet
	3" (80 mm)	240 - 4000	3647.2462.xxxx	60	10
	6" (150 mm)	240 - 4000	5163.3687.xxxx	60	10

Grit / Grain: 240, 360, 500, 600, 800, 1000, 1500, 2000, 3000, 4000

	Protection Pads Disques de protection				
	Size Dimension	Part Number Num produit	Case Caisse	Sleeve Paquet	
	5-11/16" (145 mm)	0020.3453	10	2	



7240 siacarat

Hand Sanding Pads for siafast Discs

Plateaux de ponçage manuel pour disques siafast

1-3/8" (35 mm)		
	Hardness Dureté	Part Number Numéro de produit
	Soft / Hard Mou / Dur	0020.3285 Useable on both sides Utilisable sur deux côtés



5" (125 mm)		
	Hardness Dureté	Part Number Numéro de produit
	Soft Mou	067F.2997

5" (125 mm)		
	Hardness Dureté	Part Number Numéro de produit
	Soft Mou	050F.1257

6" (150 mm)		
	Hardness Dureté	Part Number Numéro de produit
	Soft Mou	0020.0364

6" (150 mm)		
	Hardness Dureté	Part Number Numéro de produit
	Soft Mou	066F.1327

Pads with shaft for siafast Discs

pour disques siafast

Plateaux avec tige



Back Pads with 1/4" Shaft for siafast Discs Plateaux avec tige 6 mm pour disques siafast & siaklett				
	Size Dimension	Hardness Dureté	Part Number Num produit	Sleeve Paquet
	2" (50 mm)	Hard Dur	036F.7883	1
	3" (75 mm)	Hard Dur	037F.7984	1
	5" (125 mm)	Medium Moyen	038F.7987	1

Pads for siafast Discs disques siafast

Plateaux pour

1-1/4" (32 mm)		
	Hardness Dureté	Part Number Num produit
	Soft Mou	0020.1839
	Fastener Attache	5 / 16"
	Max. RPM	10 000 RPM

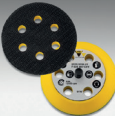
3" (77 mm)	6 holes / 6 trous	
	Hardness Dureté	Part Number Num produit
	Soft Mou	0020.9299
	Fastener Attache	5 / 16"
	Max. RPM	10 000 RPM

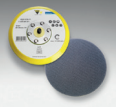
5" (125 mm)	No hole / Sans trou	
	Hardness Dureté	Part Number Num produit
	Soft Mou	0020.6730
	Hard Dur	0020.6731
	Fastener Attache	5 / 16"
	Max. RPM	12 000 RPM

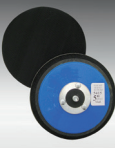
5" (125 mm)	No hole / Sans trou	
	Hardness Dureté	Part Number Num produit
	Medium Moyen	022F.4268
	Fastener Attache	5 / 16"
	Max. RPM	12 000 RPM

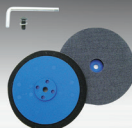
5" (125 mm)	No hole / Sans trou	
	Hardness Dureté	Part Number Num produit
	Soft Mou	032U.2283
	Fastener Attache	5 / 16"
	Max. RPM	10 000 RPM

5" (125 mm)	No hole / Sans trou	
	Hardness Dureté	Part Number Num produit
	Medium Moyen	025F.6304
	Fastener Attache	5 / 16"
	Max. RPM	10 000 RPM

5" (125 mm)	No hole / Sans trou	
	Hardness Dureté	Part Number Num produit
	Med - Hard Moy - dur	005F.6817
	Fastener Attache	5 / 16"
	Max. RPM	10 000 RPM

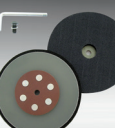
5" (125 mm)	No hole / Sans trou	
	Hardness Dureté	Part Number Num produit
	Med - Hard Moy - dur	030U.3178
	Fastener Attache	5 / 16"
	Max. RPM	10 000 RPM

5" (125 mm)	5 holes / 5 trous	
	Hardness Dureté	Part Number Num produit
	Extra soft Extra mou	0020.0537
	Med - Hard Moy - Dur	0020.2045
	Fastener Attache	5 / 16"
	Max. RPM	10 000 RPM

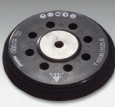
5" (125 mm)	8 holes / 8 trous	
	Hardness Dureté	Part Number Num produit
	Extra soft Extra mou	0020.0540
	Hard Dur	0020.0539
	Fastener Attache	5 / 16"
	Max. RPM	10 000 RPM

Pads for siafast Discs pour disques siafast

Plateaux

5" (125 mm)	8 holes / 8 trous	
	Hardness Dureté	Part Number Num produit
	Soft Mou	0020.4744
	Fastener Attache	5 / 16"
	Max. RPM	10 000 RPM

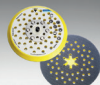
5" (125 mm)	54 holes / 54 trous	
	Hardness Dureté	Part Number Num produit
	Soft Mou	0020.6728
	Hard Dur	0020.6729
	Fastener Attache	5 / 16"
	Max. RPM	12 000 RPM

6" (150 mm)	No hole / Sans trou	
	Hardness Dureté	Part Number Num produit
	Soft Mou	0020.0346
	Fastener Attache	5 / 16"
	Max. RPM	10 000 RPM

6" (150 mm)	No hole / Sans trou	
	Hardness Dureté	Part Number Num produit
	Soft Mou	0020.6736
	Hard Dur	0020.6737
	Fastener Attache	5 / 16"
	Max. RPM	12 000 RPM

6" (150 mm)	No hole / Sans trou	
	Hardness Dureté	Part Number Num produit
	Medium Moyen	0020.0073
	Fastener Attache	5 / 8" - 11
	Max. RPM	5 500 RPM

6" (150 mm)	No hole / Sans trou	
	Hardness Dureté	Part Number Num produit
	Medium Moyen	027F.2673
	Fastener Attache	5 / 16"
	Max. RPM	10 000 RPM

	No hole / Sans trou	
	Med-Hard Moy-dur	
	Fastener Attache	5 / 16"
	Max. RPM	7 700 RPM

6" (150 mm)	No hole / Sans trou	
	Hardness Dureté	Part Number Num produit
	Medium Moyen	0020.0345
	Fastener Attache	5 / 16"
	Max. RPM	12 000 RPM

6" (150 mm)	15 holes / 15 trous	
	Hardness Dureté	Part Number Num produit
	Soft Mou	0020.4740
	Fastener Attache	5 / 16"
	Max. RPM	10 000 RPM

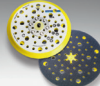
	54 holes / 54 trous	
	Soft Mou	
	Hard Dur	
	Fastener Attache	5 / 16"
	Max. RPM	12 000 RPM

Pad for siafast Discs disques siafast

Plateaux pour

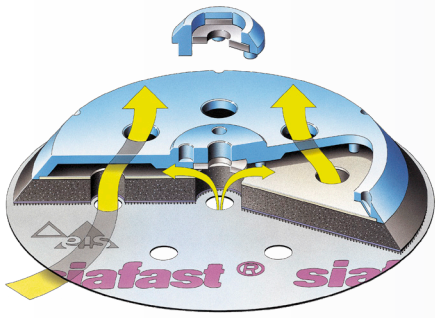

Useful color code code de couleur utile	
Extra soft Extra mou	Orange Orange
Soft Mou	Blue Bleu
Hard Dur	Black Noir

6" (150 mm)	103 holes / 103 trous	
	Hardness Dureté	Part Number Num produit
	Extra soft Extra mou	0020.5742
	Fastener Attache	5 / 16"
	Max. RPM	7 700 RPM

6" (150 mm)	103 holes / 103 trous	
	Hardness Dureté	Part Number Num produit
	Soft Mou	0020.5740
	Fastener Attache	5 / 16"
	Max. RPM	12 000 RPM

6" (150 mm)	103 holes / 103 trous	
	Hardness Dureté	Part Number Num produit
	Hard Dur	0020.5741
	Fastener Attache	5 / 16"
	Max. RPM	12 000 RPM



8" (200 mm)	No hole / Sans trou	
	Thickness Épaisseur	Part Number Num produit
	Medium Moyen	067F.0200
	Fastener Attache	5 / 8" - 11
	Max. RPM	4 700 RPM

8" (200 mm)	No hole / Sans trou	
	Hardness Dureté	Part Number Num produit
	Soft Mou	031U.1286
	Medium Moyen	0020.0357
	Fastener Attache	5 / 8" - 11
	Max. RPM	3 800 / 4 700 RPM

(5/8 - 11)	Size Dimension	Hardness Dureté	Max RPM	Part Number No produit	sleeve paquet
	4-1/2" (115 mm)	Med-Hard Moy - dur	11000	0020.0180	2
	5" (125 mm)	Hard Dur	10000	0020.0181	2
	6" (150 mm)	Hard Dur	10000	0020.0182	2
	7" (180 mm)	Hard Dur	8 500	0020.0183	2

Intermediate Pads - Plateaux intermédiaires

No hole / Sans trou				
	Size Dimension	thickness	Part Number Num produit	sleeve paquet
	3" (77 mm)	1/2" (12 mm)	0020.0269	1
	5" (125 mm)	3/4" (20 mm)	063F.1724	1
	6" (150 mm)	3/4" (20 mm)	064F.6319	1

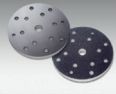
5" (125 mm) 15 holes / 15 trous		
	Thickness Épaisseur	Part Number Num produit
	3/8" (10 mm)	0020.3193

3" (77 mm) 6 holes / 6 trous					
	Diameter Diamètre	Thickness Épaisseur	Part Number No produit	Case Caisse	Sleeve Paquet
	3" (77 mm)	1 mm	0020.8123	10	1
		5 mm	0020.8259	10	1

103 holes / 103 trous		
	3/8" (10 mm)	

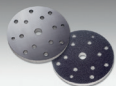
6" (150 mm) 15 holes / 15 trous		
	Thickness Épaisseur	Part Number Num produit
	1/2" (12 mm)	0020.4546

5" (125 mm) 45 holes / 45 trous		
	Thickness Épaisseur	Part Number Num produit
	1 mm	0020.8124

103 holes / 103 trous		
	1 mm	

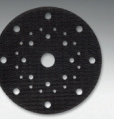
6" (147 mm) 33 holes / 33 trous (microklett)		
	Thickness Épaisseur	Part Number Num produit
	3/64" (1 mm)	0020.7428

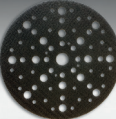
6" (147 mm) 69 holes / 69 trous (microklett)		
	Thickness Épaisseur	Part Number Num produit
	3/64" (1 mm)	0020.9147

Plain Discs

Disques réguliers

1707 siapar	Silicon Carbide (paper / cloth) Carbure silicium (papier / toile)				
	Size Dimension	Grit Grain	Part Number Num produit	Case Caisse	Sleeve Paquet
	7" x 7/8" (178 x 22 mm)	016 - 036	4152.4162.xxxx	250	25
		040 - 150	4152.4162.xxxx	500	50

Grit / Grain: 16, 24, 36, 40, 50, 60, 80, 100, 120, 150

Applications

Concrete, wood (solid, varnished)
Ciment, bois (massif, vernis)

Series Available for siafix Discs

Séries disponibles pour disques

Series Séries	Grit Range Granulométrie	Type of Grit Type de grain	Type of Backing Type de support	Applications Applications
2511 siabite	36 - 120	Ceram. / alox Céram. / cor.	Cloth Toile	Metals, stainless steels Métaux, acier inoxydable
2803 siaron	36 - 120	Zirc. & alum. Ox. Zirc. & Corindon	Cloth Toile	High alloys steels Acier hautement alliés
2820 siamet	36 - 320	Zirc. & alum. Ox. Zirc. & Corindon	Cloth Toile	Metals, steels Métaux, aciers
2925 sialox	24 - 320	Aluminum Ox. Corindon	Cloth Toile	Ferrous & non ferrous metals, plastics Métaux ferreux, non-ferreux, plastiques

Accessories for siafix Discs are shown on Page 56
Les accessoires pour les disques siafix sont disponibles à la page 56

siafix Discs - Disques siafix

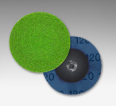

2511 siabite	Ceramic Céramic				r-loc	s-loc m
	Size Diamètre	Grit Grain	Case Caisse	Sleeve Paquet	P. Number N. produit	P. Number N. produit
	2" (50 mm)	36 - 120	500	50	8185.7250	5115.4528
	3" (75 mm)	36 - 120	500	50	8734.9195	5664.6473

Grit / Grain: 36, 50, 60, 80, 120

*Ajoutez .xxxx à la fin du numéro de produit pour indiquer votre grain.
*Add .xxxx at the end of the part number to indicate your grit.

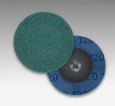
2803 siaron	Zirconia Zirconium				r-loc	s-loc m
	Size Diamètre	Grit Grain	Case Caisse	Sleeve Paquet	P. Number N. produit	P. Number N. produit
	2" (50 mm)	36 - 180	500	50	4546.6124	1476.3402
	3" (75 mm)	36 - 180	500	50	5074.1848	2003.9126

Grit / Grain: 36, 40, 60, 80, 120

*Ajoutez .xxxx à la fin du numéro de produit pour indiquer votre grain.
*Add .xxxx at the end of the part number to indicate your grit.

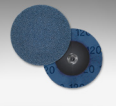
2820 siamet	Zirconia Zirconium				r-loc	s-loc m
	Size Diamètre	Grit Grain	Case Caisse	Sleeve Paquet	P. Number N. produit	P. Number N. produit
	2" (50 mm)	36 - 320	500	50	4917.8786	1847.6064
	3" (75 mm)	36 - 320	500	50	5445.4510	2375.1788

Grit / Grain: 36, 40, 50, 60, 80, 120, 180, 240, 320

*Ajoutez .xxxx à la fin du numéro de produit pour indiquer votre grain.
*Add .xxxx at the end of the part number to indicate your grit.

2925 sialox	Aluminum Oxide Corindon				r-loc	s-loc m
	Size Diamètre	Grit Grain	Case Caisse	Sleeve Paquet	P. Number N. produit	P. Number N. produit
	2" (50 mm)	24 - 320	500	50	7184.2947	4114.0225
	3" (75 mm)	24 - 320	500	50	7711.8671	4641.5949

Grit / Grain: 24, 36, 40, 50, 60, 80, 120, 180, 240, 320

*Ajoutez .xxxx à la fin du numéro de produit pour indiquer votre grain.
*Add .xxxx at the end of the part number to indicate your grit.

Series Available for siafix Nonwoven Discs

Séries disponibles pour disques siafix non tissé



Series Séries	Grade Grade	Type of Grit Type de grain	Type of Backing Type de support	Applications Applications
6250 SCM	X-coarse - s-fine X-rude - s-fin	Al Ox / Sil Carb Cor. / Carb.sil	Nonwoven (Nylon) Non tissé (nylon)	Steels, Stainless, aluminum Aciers, inox, aluminium
6924 siamet hd	X-coarse - Med X-rude - Moyen	Al Ox / Sil Carb Cor. / Carb.sil	Nonwoven (Nylon) Non tissé (nylon)	Non alloy & high allow steels Aciers non alliés ou fortement alliés
6300 siastrip	Extra coarse Extra rude	Al Ox / Sil Carb Cor. / Carb.sil	Nonwoven (Nylon) Non tissé (nylon)	Steel, stainless steel, aluminum Acier, acier inoxydable, aluminium
siaspectrum	Medium - V-fine Moyen - Très fin	Al Ox / Sil Carb Cor. / Carb.sil	Nonwoven (Nylon) Non tissé (nylon)	Metal Métaux

Accessories for siafix Discs are shown on Page 56
Les accessoires pour les disques siafix sont disponibles à la page 56

6250 SCM	SCM				r-loc	s-loc m
	Dia. Dia.	Grade Grade	Case Caisse	Sleeve Paquet	P. Number N. produit	P. Number N. produit
	2" (50 mm)	X-Coarse X-Rude	300	50	5903.6105.1922	8314.0259.1922
		Coarse Rude	300	50	5903.6105.2922	8314.0259.2922
		Medium Moyen	300	50	5903.6105.4922	8314.0259.4922
		Veryfine Très fin	300	50	5903.6105.6922	8314.0259.6922
		Superfine Super fin	300	50	1416.5100.7714	8314.0259.7714
	3" (75 mm)	X-Coarse X-Rude	100	25	6452.8050.1922	8863.2204.1922
		Coarse Rude	100	25	6452.8050.2922	8863.2204.2922
		Medium Moyen	100	25	6452.8050.4922	8863.2204.4922
		Veryfine Très fin	100	25	6452.8050.6922	8863.2204.6922
		Superfine Super fin	100	25	1965.7045.7714	8863.2204.7714

6924 siamet hd	SCM-HD				r-loc	s-loc m
	Dia. Dia.	Grade Grade	Case Caisse	Sleeve Paquet	P. Number N. produit	P. Number N. produit
	2" (50 mm)	X-Coarse X-Rude	500	50	0546.3989.1923	2956.8143.1923
		Coarse Rude	500	50	0546.3989.2923	2956.8143.2923
		Medium Moyen	500	50	0546.3989.4923	2956.8143.4923
	3" (75 mm)	X-Coarse X-Rude	500	50	1073.9713.1923	3506.0088.1923
		Coarse Rude	500	50	1073.9713.2923	3506.0088.2923
		Medium Moyen	500	50	1073.9713.4923	3506.0088.4923

6300	siastrip				r-loc	s-loc m
	Dia. Dia.	Grade Grade	Case Caisse	Sleeve Paquet	P. Number N. produit	P. Number N. produit
	2" (50 mm)	X-Coarse X-Rude	100	10	1715.2309.1721	8612.7001.1721
	3" (75 mm)	X-Coarse X-Rude	100	10	2242.7566.1721	9140.2725.1721

	Spectrum Unitized Wheels Roues «unitized» Spectrum				r-loc
	Dia. Dia.	Grade Grade	Colour Couleur	Sleeve Paquet	P. Number N. produit
	2" (50 mm)	Medium Moyen	Red Rouge	60	5999.2104
		Fine Fin	Gray Gris	60	5999.2103
		Extrafine Extra fin	Blue Bleu	60	5999.2102
		Very Fine Très fin	Green Vert	60	5999.2101
	3" (75 mm)	Medium Moyen	Red Rouge	20	5999.2109
		Fine Fin	Gray Gris	20	5999.2108
		Extrafine Extra fin	Blue Bleu	20	5999.2107
		Very Fine Très fin	Green Vert	52	5999.2106

HOLDERS - Supports



siafix Holder Support siafix					r-loc	s-loc m
	Size Diamètre	Hardness Dureté	Case Caisse	Sleeve Paquet	P. Number N. produit	P. Number N. produit
	3/4" (20 mm)	Medium Moyen	5	1	0020.8063.01	0020.8072.01
	1" (25 mm)	Medium Moyen	5	1	0020.8064.01	0020.8073.01
	1-1/2" (38 mm)	Medium Moyen	5	1	0020.8065.01	0020.8074.01
	2" (50 mm)	Soft Mou	5	1	0020.8067.01	0020.8076.01
		Medium Moyen	5	1	0020.8066.01	0020.8075.01
		Hard Dur	5	1	0020.8068.01	0020.8077.01
	3" (75 mm)	Soft Mou	5	1	0020.8070.01	0020.8079.01
		Medium Moyen	5	1	0020.8069.01	0020.8078.01
		Hard Dur	5	1	0020.8071.01	0020.8080.01



Series Available Fiber Discs disponibles pour disques de fibre

Séries

Series Série	Grit Range Granulométrie	Type of Grit Type de grain	Type of Backing Type de support	Applications Applications
4570 siabiteX	36 - 80	Ceramic Céramique	Carbon Fiber Fibre de carbone	Stainless steel, high alloy steels Inox, métaux hautement alliés
4700 siaral 8	16 - 320	Silicon Carbide Carbure silicium	Carbon Fiber Fibre de carbone	Stainless steel, non ferrous, steels Inox, métaux non ferreux, aciers,
4815 siabite	24 - 150	Zirconia Zirconium	Carbon Fiber Fibre de carbone	Stainless steel, mild steels Inox, aciers hautement alliés
4819 siaron 8	24 - 150	Zirconia Zirconium	Carbon Fiber Fibre de carbone	Stainless steel, mild steels, aluminum, non ferrous Inox, acier, aluminium, métaux non ferreux,
4961 sialoX	16 - 120	Aluminum Oxide Corindon	Carbon Fiber Fibre de carbone	Mild steels, aluminum, non ferrous Acier, aluminium, métaux non ferreux,

Accessories for Fiber Discs are shown on Page 58
Les accessoires pour les disques de fibre sont disponibles à la page 58

Fiber Discs - Disques de fibre

4570 siabiteX		Ceramic C�ramique			
	Size Dimension	Grit Grain	Part Number Num produit	Case Caisse	Sleeve Paquet
	4" x 5/8" (100 x 16 mm)	36 - 120	5369.8301.xxxx	200	50
	4-1/2" x 7/8" (115 x 22 mm)	36 - 120	1737.3366.xxxx	200	50
	5" x 7/8" (125 x 22 mm)	36 - 120	1935.3923.xxxx	200	50
	7" x 7/8" (180 x 22 mm)	36 - 120	1426.9972.xxxx	200	50

Grit / Grain: 36, 60, 80, 120

4700 sialar 8		Silicone Carbide Carbure silicium			
	Size Dimension	Grit Grain	Part Number Num produit	Case Caisse	Sleeve Paquet
	4" x 5/8" (100 x 16 mm)	024	1278.5025.0024	150	25
		036 - 120	1278.5025.xxxx	200	50
	4-1/2" x 7/8" (115 x 22 mm)	024	4543.3400.0024	150	25
		036 - 80	4543.3400.xxxx	200	50
		120	3327.8302.0120	200	50
	5" x 7/8" (125 x 22 mm)	024 - 120	4763.0178.xxxx	200	50
		024	3135.1630.xxxx	150	25
	7" x 7/8" (180 x 22 mm)	036	3135.1630.0036	200	50
		060 - 120	4233.0006.xxxx	200	50

Grit / Grain: 24, 36, 60, 80, 120

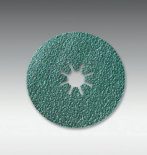
4815 siabite		Zirconia Zirconium			
	Size Dimension	Grit Grain	Part Number Num produit	Case Caisse	Sleeve Paquet
	4-1/2" x 7/8" (115 x 22 mm)	036 - 150	7025.6097.xxxx	200	50
	5" x 7/8" (125 x 22 mm)	036 - 150	7245.2875.xxxx	200	50
	7" x 7/8" (180 x 22 mm)	036 - 150	6715.2236.xxxx	200	50

Grit / Grain: 36, 60, 80, 100, 120, 150

4961 sialoX		Aluminum Oxide Corindon			
	Size Dimension	Grit Grain	Part Number Num produit	Case Caisse	Sleeve Paquet
	4" x 5/8" (100 x 16 mm)	024	3854.6295.0024	150	25
		036 - 120	3854.6295.xxxx	200	50
	4-1/2" x 7/8" (115 x 22 mm)	024	0222.1827.0024	150	25
		036 - 120	0222.1827.xxxx	200	50
	5" x 7/8" (125 x 22 mm)	024	0441.8605.0024	150	25
		036 - 120	0441.8605.xxxx	200	50
7" x 7/8" (180 x 22 mm)	024	9879.5847.0024	150	25	
	036 - 120	9879.5847.xxxx	200	50	

Grit / Grain: 24, 36, 60, 80, 120

4819 siaron		Zirconia Zirconium			
	Size Dimension	Grit Grain	Part Number Num produit	Case Caisse	Sleeve Paquet
	4-1/2" x 7/8" (115 x 22 mm)	024	7120.5813.0024	150	25
		036 - 120	7120.5813.xxxx	200	50
	5" x 7/8" (125 x 22 mm)	024	7340.2591.0024	150	25
		036 - 120	7340.2591.xxxx	200	50
	7" x 7/8" (180 x 22 mm)	024	5712.4043.0024	150	25
		036 - 120	5712.4043.xxxx	200	50

Grit / Grain: 24, 36, 60, 80, 120



Fiber discs with 5-/8" Hub
Disque de fibre avec un coeur 5/8

These fiber discs are available upon request

Ces disques de fibre sont disponibles sur demande

Pads for Fiber Discs - Plateaux pour disques de fibre

Back Pads for Fiber discs Plateaux pour disques de fibre (5/8" - 11)

	Size Dimension	Hardness Dureté	Max RPM	Part Number Num produit	Sleeve Paquet
	4" (100 mm)	Hard Dur	13 000	114F.0100	1
	4-1/2" (115 mm)	Hard Dur	13 000	2611.8981	1
	5" (125 mm)	Hard Dur	12 000	0020.0431	1
	7" (180 mm)	Hard Dur	8 500	0020.0432	1

	5" (125 mm)	Hard Dur	12 000	1
	7" (180 mm)	Hard Dur	8 500	1

	4-1/2" (115 mm)	Hard Dur	13 000		1
	5" (125 mm)	Hard Dur	12 000		1
	7" (180 mm)	Hard Dur	8 500		1

Usage Guide / Guide d'utilisation

Type of Pad Type de plateau	Grit / grain
Plain - régulier	100 - 120
Turbo I	50 - 80
Turbo II	36 - 60



4570 siabite X



a polyvalent fastening system - just one click....
un système de fixation polyvalent - juste un clic....

X-LOCK The ultimate disc changing system. Just One Click. **X-LOCK** L'ultime système de changement de disque.

Just One Click. Easy change of abrasives without additional mounting equipment. Up to 5x faster compared to conventional changing solutions.

Juste Un Clic. Changement facile d'abrasifs sans équipement de montage supplémentaire. Jusqu'à 5x plus rapide que les solutions conventionnelles.

Products for all angle grinder applications Pour toutes les applications de meulage d'angle

We offer an optimized range of cutting and grinding discs, flap discs, fibre discs, and SCM discs which provide excellent solutions for General Fabrication applications.

Nous offrons une gamme optimisée de disques de coupe et de rectification, disques à lamelles, disques de fibre et SCM qui offrent d'excellentes solutions pour les applications générales.



Adds value to sia 2-Step Solution Ajoute de la valeur à la solution 2 étapes

The advantages of the innovative Bosch **X-LOCK** System in combination with our outstanding product performance brings the sia 2 Step Solution to a new level. Les avantages du système innovant Bosch **X-LOCK** en combinaison avec notre remarquable performance du produit amène la solution sia 2 Step à un nouveau niveau

- Work more efficiently
- Saves time
- Grind at a flat angle
- Not damage the surfaces caused by the clamping nut
- Determines the mounting direction of the accessories
- Ensures that directional discs correctly mounted.
- Comprehensive range of accessories for every application

- Travail plus efficace
- Économie de temps
- Meule à angle plat
- N'endommage pas les surfaces causé par l'écrou de serrage
- Détermine la direction de montage des accessoires
- S'assure que les disques sont correctement montés
- Gamme complète d'accessoires pour toutes les applications





2824 T-29 X-LOCK					
Zirconia Flap Discs (plastic backed) Disques à lamelles en zirconium (endos de plastique)					
	Diameter Diamètre	Grit Grain	Part Number No. produit	Case Caisse	Sleeve Paquet
Flat / Plat					
	4-1/2" x 8/13" (115 x XX mm)	40	0020.8912	60	10
		60	0020.8913	60	10
		80	0020.8914	60	10
		120	0020.8915	60	10
	5" x 8/13" (125 x XX mm)	40	0020.8916	60	10
		60	0020.8917	60	10
		80	0020.8918	60	10
		120	0020.8919	60	10

Carbon Fiber Discs (ceramic) Disques de fibre de carbone (céramique)					
	Diameter Diamètre	Grit Grain	Part Number No. produit	Case Caisse	Sleeve Paquet
	4-1/2" x 7/8" (115 x 22 mm)	36 - 120		200	50
	5" x 7/8" (125 x 22 mm)	36 - 120		200	50
36, 50, 60, 80, 100, 120					

Standard Backing Pad for Fiber Discs Plateaux standard pour disques de fibre					
	Diameter Diamètre	Hardness Dureté	Part Number No. produit	Case Caisse	Sleeve Paquet
	4-1/2" (115 mm)	Soft Souple			
	5" (125 mm)	Soft Souple			

X-LOCK Turbo Backing Pad for Fiber Discs Plateaux Turbo pour disques de fibre					
	Size Dimension	Hardness Dureté	Max RPM	Part Number No. produit	Sleeve Paquet
	4-1/2" (115 mm)	Medium Moyen		0020.9562	1
		Hard Dur		0020.9564	1
	5" (125 mm)	Medium Moyen		0020.9563	1
		Hard Dur		0020.9565	1

X-LOCK Backing Pad with Center Pin for SCM Discs Plateaux pour disques SCM avec trou central					
	Size Dimension	Hardness Dureté	Max RPM	Part Number No. produit	Sleeve Paquet
	4-1/2" (115 mm)			0020.9566	1
	5" (125 mm)			0020.9567	1

8913 siacut X-LOCK						
Cut off wheels Disques de coupe						
	Diameter Diamètre	Thickness Épaisseur	Bore Arbre	Part Number No. produit	Grade Grade	Sleeve Paquet
	4-1/2" (115 mm)	3/64" (1,0 mm)	7/8" (22,23 mm)	0020.8742	-	25
	5" (125 mm)	3/64" (1,0 mm)	7/8" (22,23 mm)	0020.8743	-	25

8933 siagrind -LOCK						
Grinding Discs Meules						
	Diameter Diamètre	Thickness Épaisseur	Bore Arbre	Part Number No. produit	Grade Grade	Sleeve Paquet
	4-1/2" (115 mm)	1/4" (6,0 mm)	7/8" (22,23 mm)	0020.8744	-	25
	5" (125 mm)	1/4" (6,0 mm)	7/8" (22,23 mm)	0020.8745	-	25

6300 siastrip Discs Disques 6300 siastrip						
	Diameter Diamètre	Thickness Épaisseur	Bore Arbre	Part Number No. produit	Grade Grade	Sleeve Paquet
	4-1/2" x 7/8" (115 x 22 mm)	x-coarse x-rude				10
	5" x 7/8" (125 x 22 mm)	x-coarse x-rude				10



Just One Click
Juste Un Clic



A close-up photograph of a hand wearing a green work glove operating a grey angle grinder. The grinder is equipped with a blue flap disc, which is being used to grind a metal surface. Bright sparks are visible as the disc makes contact with the metal. The background is a blurred industrial setting.

FLAP DISCS DISQUES À LAMELLES

Flap Discs - Disques à lamelles

2500

(Ceramic / Céramique)

The innovative abrasive for a fast removal rate

L'abrasif innovant pour un enlèvement de matière rapide

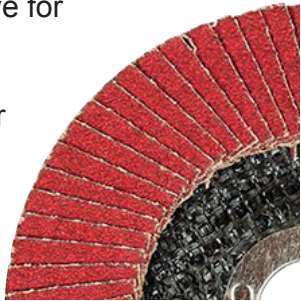

2824 siaflap

Eco

(Zirconia / Zirconium)

High-performance flap discs for high-alloy steel

Disques performants pour l'acier hautement allié

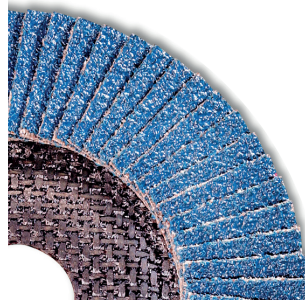

2824 siaflap Jumbo

(Zirconia / Zirconium)

A high-performance product for industrial needs.

Produit performant destiné à l'industrie



2824 siaflap Standard

(Zirconia / Zirconium)

A tool for series processing with very high strength.

Outil haute résistance pour l'usinage en série

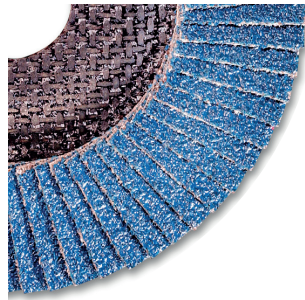

Eco



Standard

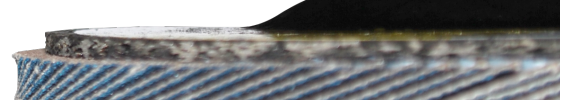

Jumbo

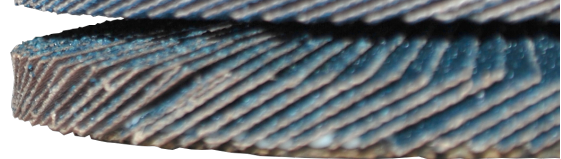





Combi Flap Discs:



To Grind Down Weld Seams & Provide a Flawless Finish in One Single Operation

Disque à lamelles COMBI:

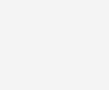

Pour Meuler un cordon de soudure et obtenir une finition irréprochable en une seule opération



Flap Discs - Disques à lamelles



2500	Ceramic (fiber glass) Céramique (fibre de verre)				
	Diameter Diamètre	Grit Grain	Part Number Num produit	Case Caisse	Sleeve Paquet
	 Angled / Bombé (T29)				
	4-1/2" x 7/8" (115 x 22 mm)	36	074E.0036	60	10
		40	074E.0040	60	10
		60	074E.0060	60	10
		80	074E.0080	60	10
120		074E.0020	60	10	
5" x 7/8" (125 x 22 mm)	36	076E.0036	60	10	
	40	076E.0040	60	10	
	60	076E.0060	60	10	
	80	076E.0080	60	10	
	 Flat / Plat (T27)				
	4-1/2" x 7/8" (115 x 22 mm)	40	072E.0040	60	10
		60	072E.0060	60	10
	5" x 7/8" (125 x 22 mm)	40	075E.0040	60	10
		46	075E.0060	60	10
80		075E.0080	60	10	



2500	Ceramic (plastic) Céramique (fibre de verre)				
	Diameter Diamètre	Grit Grain	Part Number Num produit	Case Caisse	Sleeve Paquet
	 Angled / Bombé (T29)				
	5" x 7/8" (125 x 22 mm)	40	077E.0040	60	10
		60	077E.0060	60	10
		80	077E.0080	60	10

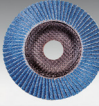

2820	siaflap siafix Zirconia Zirconium				
	Diameter Diamètre	Grit Grain	Part Number Num produit	Case Caisse	Sleeve Paquet
	2" (50 mm)	040	0020.4323	200	20
		060	0020.4324	200	20
		080	0020.4325	200	20

2824 standard	Zirconia (plastic backed) Zirconium (support plastique)				
	Diameter Diamètre	Grit Grain	Part Number Num produit	Case Caisse	Sleeve Paquet
	 Flat / Plat (T27)				
	4-1/2" x 7/8" (115 x 22 mm)	40	0020.4361	60	10
		60	0020.4363	60	10
		80	0020.4364	60	10
		120	0020.4365	60	10
5" x 7/8" (125 x 22 mm)	40	0020.4387	60	10	
	60	0020.4389	60	10	
	80	0020.4390	60	10	
	120	0020.4391	60	10	
6" x 7/8" (150 x 22 mm)	40	Z506.0047	60	10	
	7" x 7/8" (180 x 22 mm)	40	0020.4409	30	5
60		0020.4411	30	5	
80		0020.4412	30	5	

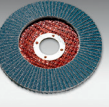
2824 Eco	Zirconia (fiber glass) Zirconium (fibre de verre)				
	Diameter Diamètre	Grit Grain	Part Number Num produit	Case Caisse	Sleeve Paquet
	 Angled / Bombé (T29)				
	4-1/2" x 7/8" (115 x 22 mm)	40	0020.4901	60	10
		60	0020.5456	60	10
		80	0020.5771	60	10
5" x 7/8" (125 x 22 mm)	40	0020.4900	60	10	
	60	0020.5457	60	10	
	80	0020.5772	60	10	

2824 standard	Zirconia (fiber glass) Zirconium (fibre de verre)				
	Diameter Diamètre	Grit Grain	Part Number Num produit	Case Caisse	Sleeve Paquet
	 Flat / Plat (T27)				
	4-1/2" x 7/8" (115 x 22 mm)	40	0020.4373	60	10
		60	0020.4375	60	10
		80	0020.4376	60	10
120		0020.4377	60	10	
5" x 7/8" (125 x 22 mm)	40	0020.4399	60	10	
	60	0020.4401	60	10	
	80	0020.4402	60	10	
	120	0020.4403	60	10	

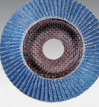
2824 Jumbo	Zirconia (fiber glass) Zirconium (fibre de verre)				
	Diameter Diamètre	Grit Grain	Part Number Num produit	Case Caisse	Sleeve Paquet
	 Angled / Bombé (T29)				
	4-1/2" x 7/8" (115 x 22 mm)	40	0020.2922	60	10
		60	0020.2923	60	10
		80	0020.2924	60	10
5" x 7/8" (125 x 22 mm)	40	0020.3021	60	10	
	60	0020.3022	60	10	
	80	0020.3023	60	10	

2824 standard	Zirconia (fiber glass) Zirconium (fibre de verre)				
	Diameter Diamètre	Grit Grain	Part Number Num produit	Case Caisse	Sleeve Paquet
	 Angled / Bombé (T29)				
	4" x 5/8" (100 x 15 mm)	36	073E.0036		5
4-1/2" x 7/8" (115 x 22 mm)	40	0020.2651	60	10	
	60	0020.2653	60	10	
	80	0020.2655	60	10	
5" x 7/8" (125 x 22 mm)	40	0020.2657	60	10	
	60	0020.2659	60	10	
	80	0020.2661	60	10	
7" x 7/8" (180 x 22 mm)	40	0020.3025	30	5	
	60	0020.3027	30	5	
	80	0020.3028	30	5	

Flap Discs COMBI - Disques à lamelles COMBI

Flap Discs COMBI Disques à lamelles COMBI					
	4-1/2" x 7/8" (115 x 22,3 mm)	Ultra Coarse Ultra rude	5000 - 6000 RPM	10	
		X-coarse X-rude	5000 - 6000 RPM	10	
		Coarse Rude	5000 - 6000 RPM	10	
		Medium Moyen	5000 - 6000 RPM	10	
		Veryfine Très fin	5000 - 6000 RPM	10	
	5" x 7/8" (125 x 22,3 mm)	Ultra Coarse Ultra rude	5000 - 6000 RPM	10	
		X-coarse X-rude	5000 - 6000 RPM	10	
		Coarse Rude	5000 - 6000 RPM	10	
		Medium Moyen	5000 - 6000 RPM	10	
		Veryfine Très fin	5000 - 6000 RPM	10	



Properties

- A perfect match between 2 technically advanced abrasive materials with varying abrasive capacities
- Surface conditioning with a very rapid and even grinding capacity
- Polycotton extra flexible abrasive cloth with grinding aid
- Even wear of both the Surface Conditioning Material and the abrasive cloth
- Shock reducing effect

Propriétés

- Mariage parfait entre deux abrasifs différents (conditionneur de surface et toile abrasive)
- Un conditionneur de surfaces avec capacité d'ébarbage très rapide
- Toile abrasive en polycoton très flexible avec un additif activant l'abrasif
- Usure égale entre le conditionneur de surface et la toile abrasive
- Effet amortissant et agréable à l'usage

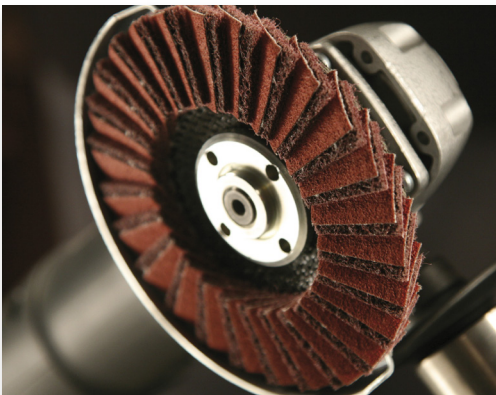

Advantages

Important time saving:
Remove a weld seam and get a perfect finish in only one step

Meule un cordon de soudure et donne un fini parfait en une seule opération

Controlled material removal:
No risk for gauging or for grinding flats on tubular sections

Absence de risque d'altérer la surface des pièces plates ou arrondies



Bonded Abrasifs Abrasifs Agglomérés



Cut-off Wheels tronçonner



Stainless
**Meules à
Inox**

	Diameter Diamètre	Thickness Épaisseur	Bore Arbre	Part Number No. de produit	Grade	Max. RPM	Qty / sleeve Qté / paquet
	4-1/2" (115 mm)	1/24" (1,0 mm)	7/8" (22,23 mm)	01019	A60T	13,300	50
		1/21" (1,2 mm)	7/8" (22,23 mm)	01217	A60T	13,300	50
		1/16" (1,6 mm)	7/8" (22,23 mm)	01613	A46T	13,300	50
	5" (125 mm)	1/24" (1,0 mm)	7/8" (22,23 mm)	01016	A60T	12,250	50
		1/21" (1,2 mm)	7/8" (22,23 mm)	01214	A60T	12,250	50
		1/16" (1,6 mm)	7/8" (22,23 mm)	01610	A46T	12,250	50
	6" (150 mm)	1/21" (1,2 mm)	7/8" (22,23 mm)	01215	A60T	12,250	50
	7" (180 mm)	1/16" (1,6 mm)	7/8" (22,23 mm)	01612	A60T	8,600	50
		3/32" (2,5 mm)	7/8" (22,23 mm)	02510	A46T	8,600	25
	9" (230 mm)	3/32" (2,5 mm)	7/8" (22,23 mm)	02515	A46S	6,500	25
Grade:	Abrasive / Abrasifs		Grit / Grain		Hardness / Dureté		
	A = Aluminum oxide		24 - 36 - 40 - 46 - 60 Coarse -----> Fine Grossier -----> Fin		N-P-Q-R-S-T Soft --> Hard Mou--> Dur		
	Life time Durée de vie		Cutting speed Vitesse de coupe		Content Contenu		
	Very good Très bonne		High Élevée		Fe, S & Cl (< 0,1%)		

Mandrel for 3" wheels - Mandrin pour meules 76 mm

	Shaft Tige	Bore Arbre	Part Number Numéro de produit	Qty / case Qté / caisse	Qty / sleeve Qté / paquet
	1/4" x 2" (6,35 x 52 mm)	3/8" 10 mm			1
	6 mm 52 mm	3/8" 10 mm			1



Stainless



	4-1/2" (115 mm)	1/24" (1,0 mm)	7/8" (22,23 mm)	A60S	13,300	50	
		1/21" (1,2 mm)	7/8" (22,23 mm)	A60S	13,300	50	
		1/16" (1,6 mm)	7/8" (22,23 mm)	A46S	13,300	50	
	5" (125 mm)	1/24" (1,0 mm)	7/8" (22,23 mm)	A60S	12,250	50	
		1/21" (1,2 mm)	7/8" (22,23 mm)	A60S	12,250	50	
		1/16" (1,6 mm)	7/8" (22,23 mm)	A46S	12,250	50	
	6" (150 mm)	1/16" (1,6 mm)	7/8" (22,23 mm)	A60S	12,250	50	
	A = Aluminum oxide		24 - 36 - 40 - 46 - 60 Coarse -----> Fine Grossier -----> Fin		N-P-Q-R-S-T Soft --> Hard Mou--> Dur		
	Life time Durée de vie		Cutting speed Vitesse de coupe		Content Contenu		
Very good Très bonne		High Élevée		Fe, S & Cl (< 0,1%)			



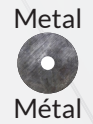

	Diameter Diamètre	Thickness Épaisseur	Bore Arbre	Part Number No. de produit	Grade	Max. RPM	Qty / sleeve Qté / paquet
	4-1/2" (115 mm)	1/24" (1,0 mm)	7/8" (22,23 mm)	01002	A60T	13,300	50
		1/21" (1,2 mm)	7/8" (22,23 mm)	01200	A60T	13,300	50
		1/16" (1,6 mm)	7/8" (22,23 mm)	01606	A46T	13,300	50
	5" (125 mm)	1/24" (1,0 mm)	7/8" (22,23 mm)	01009	A60T	12,250	50
		1/21" (1,2 mm)	7/8" (22,23 mm)	01207	A60T	12,250	50
		1/16" (1,6 mm)	7/8" (22,23 mm)	01603	A46T	12,250	50
	6" (150 mm)	1/21" (1,2 mm)	7/8" (22,23 mm)	01208	A60T	12,250	50
	7" (180 mm)	1/16" (1,6 mm)	7/8" (22,23 mm)	01605	A60T	8,600	50
		3/32" (2,5 mm)	7/8" (22,23 mm)	02503	A46T	8,600	25
	9" (230 mm)	3/32" (2,5 mm)	7/8" (22,23 mm)	02508	A46T	6,500	25
Grade:	Abrasive / Abrasifs		Grit / Grain		Hardness / Dureté		
	A = Aluminum oxide		24 - 36 - 40 - 46 - 60 Coarse -----> Fine Grossier -----> Fin		N-P-Q-R-S-T Soft --> Hard Mou--> Dur		
	Life time Durée de vie		Cutting speed Vitesse de coupe		Content Contenu		
	Very good Très bonne		High Élevée				



Cut-off Wheels tronçonner



	4-1/2" (115 mm)	1/24" (1,0 mm)	7/8" (22,23 mm)	A60S	13,300	50	
		1/21" (1,2 mm)	7/8" (22,23 mm)	A60S	13,300	50	
		1/16" (1,6 mm)	7/8" (22,23 mm)	A46S	13,300	50	
	5" (125 mm)	1/24" (1,0 mm)	7/8" (22,23 mm)	A60S	12,250	50	
		1/21" (1,2 mm)	7/8" (22,23 mm)	A60S	12,250	50	
		1/16" (1,6 mm)	7/8" (22,23 mm)	A46S	12,250	50	
	6" (150 mm)	1/16" (1,6 mm)	7/8" (22,23 mm)	A60S	12,250	50	
	A = Aluminum oxide		24 - 36 - 40 - 46 - 60 Coarse -----> Fine Grossier -----> Fin		N-P-Q-R-S-T Soft --> Hard Mou--> Dur		
	Life time Durée de vie		Cutting speed Vitesse de coupe		Content Contenu		
Very good Très bonne		High Élevée					



Grinding Wheels



Metal
Meules à ébarber
Metal

	Diameter Diamètre	Thickness Épaisseur	Bore Arbre	Part Number No. de produit	Grade	Max. RPM	Qty / sleeve Qté / paquet
	4-1/2" (115 mm)	1/4" (6,0 mm)	7/8" (22,23 mm)	60101	A24N	13,300	10
	5" (125 mm)	1/4" (6,0 mm)	7/8" (22,23 mm)	60200	A24N	12,250	10
	7" (180 mm)	1/4" (6,0 mm)	7/8" (22,23 mm)	60804	A24N	8,500	10
Grade:	Abrasive / Abrasifs		Grit / Grain		Hardness / Dureté		
	A = Aluminum oxide		24 - 36 - 40 - 46 -60 Coarse -----> Fine Grossier -----> Fin		N-P-Q-R-S-T Soft --> Hard Mou--> Dur		
	Life time Durée de vie		Cutting speed Vitesse de coupe		Content Contenu		
	Excellent Excellente		Highest Plus élevée				



A close-up photograph showing a hand wearing a dark, textured work glove. The hand is holding a rectangular, red, fibrous abrasive pad against a metallic surface. The pad has a rough, frayed texture. The background is a blurred industrial setting with metal surfaces and a dark object, possibly a shoe or part of a machine.

NONWOVEN ABRASIVES ABRASIFS NON-TISSÉS

Series Available for Nonwoven Sheets disponibles pour feuilles sur support non-tissé

Séries

Series Série	Grade Grade	Type of Grit Type de grain	Type of Backing Type de support	Applications Applications
6120 sifleece	X-coarse - microfne X-rude - micro fin	Al Ox / Sil Carb Cor / Carb sil	Nonwoven (nylon) Non tissé (nylon)	Metals, composites, varnish & paints, woods Métaux, composites, vernis & peintures, bois
6711 siavlies flex	Very fine - microfne Très fin - micro fin	Al Ox / Sil Carb Cor / Carb sil	Nonwoven (nylon) Non tissé (nylon)	Metals, composites, varnish & paints, woods Métaux, composites, vernis & peintures, bois

Nonwoven Sheets (nylon) - Feuilles sur support non-tissés (nylon)

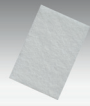
6120 siavlies	Abrasive Free / Sans abrasif					
	Size Dimension	Color Couleur	Grit Grain	Part Number Num produit	Case Caisse	Sleeve Paquet
	6" x 9" (152 x 229 mm)	White Blanc	0000	4132.9840.0051	200	10

	Aluminum Oxide / Corindon					
	Size Dimension	Color Couleur	Grade Grade	Part Number Num produit	Case Caisse	Sleeve Paquet
	6" x 9" 152 x 229 mm	Maroon Marron	Very fine Très fin		200	20
		Grey Gris	Ultra fine Ultra fin		200	20
		Yellow Jaune	Micro fine Micro fin		200	20

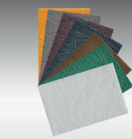
6120 siavlies	Aluminum Oxide / Corindon					
	Size Dimension	Color Couleur	Grit Grain	Part Number Num produit	Case Caisse	Sleeve Paquet
	6" x 9" (152 x 229 mm)	Tan Chamois	080	4132.9840.2922	200	10
		Green Vert	100	4132.9840.4923	200	10
		Maroon Marron	120	4132.9840.4922	200	10
		Maroon Marron	320	4132.9840.6932	200	10

6711 sifleece flex	Aluminum Oxide / Corindon					
	Size Dimension	Color Couleur	Grade Grade	Part Number Num produit	Case Caisse	Sleeve Paquet
	4-1/2" x 9" 115 x 230 mm	Red Rouge	Very fine Très fin	0948.3321.6921	200	25
Silicone Carb. / Carb. silicium						
	4-1/2" x 9" 115 x 230 mm	Grey Gris	Ultra fine Ultra fin	0948.3321.8711	200	25

	Silicone Carbide / Carburé silicium					
	Size Dimension	Color Couleur	Grit Grain	Part Number Num produit	Case Caisse	Sleeve Paquet
	6" x 9" (152 x 229 mm)	Black Noir	080	4132.9840.2721	200	10
		Black Noir	110	4132.9840.4721	200	10
		Grey Gris	600	4132.9840.8711	200	10
		Grey Gris	800	4132.9840.8712	200	10



6120 siavlies speed

Series Available for Nonwoven Belts disponibles pour bandes sur support non-tissé

Séries

Series Série	Grade Grade	Grit Grain	Colour Couleur	Type of Grit Type de grain	Applications Applications
6240 SCM	Veryfine Très fin	6921	Blue Bleu	Silicon Carb. Carb. silicium	Stainless, alloys, steels, non ferrous, aluminum Inox, alliages, aciers, non ferreux, aluminium
	Fine Fin	5921	Blue Bleu	Aluminum Ox. Corindon	Stainless, alloys, steels, non ferrous, aluminum Inox, alliages, aciers, non ferreux, aluminium
	Medium Moyen	4921	Maroon Marron	Aluminum Ox. Corindon	Stainless, alloys, steels, non ferrous, aluminum Inox, alliages, aciers, non ferreux, aluminium
	Coarse Rude	2921	Grey Gris	Aluminum Ox. Corindon	Stainless, alloys, steels, non ferrous, aluminum Inox, alliages, aciers, non ferreux, aluminium

File Belts Bandes pour limes





Width: Largeur:	From: 1/4" De: 6 mm.	To: 3/4" À: 19 mm
Grades:	From: Coarse to very Fine (60 to 600)	
Grades:	De: Rude à très fin (60 à 600)	



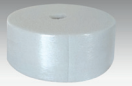

Width: Largeur:	From: 1" De: 25 mm	To: 6" À: 150 mm
Grades:	From: Coarse to very Fine (60 to 600)	
Grades:	De: Rude à très fin (60 à 600)	

Width Largeur	Length Longueur	Series Série	Part Number No. produit	Sleeve Paquet
1/4" (6 mm)	18" (457 mm)	6240 SCM	3216.2553.xxxx	48
	20" (520 mm)	6240 SCM	4591.5766.xxxx	48
	24" (610 mm)	6240 SCM	6525.3859.xxxx	48
1/2" (13 mm)	12" (305 mm)	6240 SCM	.xxxx	24
	18" (457 mm)	6240 SCM	4730.0831.xxxx	24
	20" (520 mm)	6240 SCM	6105.4044.xxxx	24
	24" (610 mm)	6240 SCM	8039.2137.xxxx	24
3/4" (19 mm)	18" (457 mm)	6240 SCM	.xxxx	16
	20-1/2" (520 mm)	6240 SCM	1478.6494.xxxx	16

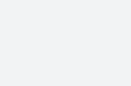
6120 siavlies	Abrasive Free Sans abrasifs					
	Size Dimension	Color Couleur	Grit Grain	Part Number Num produit	Case Caisse	Sleeve Paquet
	4" x 11 yds (100 mm x 10 m)	White Blanc	0000	9327.7238.0051	10	1

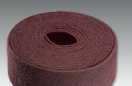
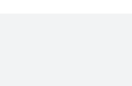
6120 siavlies	Aluminum Oxide Corindon					
	Size Dimension	Color Couleur	Grit Grain	Part Number Num produit	Case Caisse	Sleeve Paquet
	4" x 11 yds (100 mm x 10 m)	Tan Chamois	080	9327.7238.2922	10	1
		Green Vert	100	9327.7238.4923	10	1
		Maroon Marron	320	9327.7238.6932	10	1
	5" x 11 yds (125 mm x 10 m)	Green Vert	100	2344.9555.4923	10	1
		Maroon Marron	120	2344.9555.4921	10	1
		Maroon Marron	180	2344.9555.5911	10	1
		Maroon Marron	320	2344.9555.6932	10	1

6120 siavlies Speed	Aluminum Oxide Corindon					
	Size Dimension	Color Couleur	Grade Grade	Part Number Num produit	Case Caisse	Sleeve Paquet
	4" x 11 yds (100 mm x 10 m)	Maroon Marron	Very fine Très fin	9327.7238.6921	10	1
		Grey Gris	Ultrafine Ultra fin	9327.7238.8715	10	1
		Yellow Jaune	Micro- fine Micro fin	9327.7238.9913	10	1
	5" x 11 yds (125 mm x 10 m)	Maroon Marron	Very fine Très fin	2344.9555.6921	10	1
		Grey Gris	Ultrafine Ultra fin	2344.9555.8715	10	1
		Yellow Jaune	Micro- fine Micro fin	2344.9555.9913	10	1

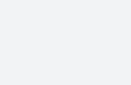
Silicone Carbide / Carbone silicium						
	Size Dimension	Color Couleur	Grit Grain	Part Number Num produit	Case Caisse	Sleeve Paquet
	4" x 11 yds (100 mm x 10 m)	Black Noir	110	9327.7238.4721	10	1
		Grey Gris	600	9327.7238.8711	10	1
	5" x 11 yds (125 mm x 10 m)	Black Noir	110	2344.9555.4721	10	1
		Grey Gris	600	2344.9555.8711	10	1
		Grey Gris	800	2344.9555.8712	10	1



6120 siavlies

Series Available for SCM Discs nibles pour disques SCM

Séries dispo-

Series Série	Grade Grade	Type of Grit Type de grain	Type of Backing Type de support	Applications Applications
6200 SCM	X-coarse - superfine X-rude - super fin	Al Ox / Sil Carb Cor. / Carb.sil	Nonwoven (nylon) Non tissé (nylon)	Steels, Stainless Aciers, inox
6250 SCM	X-coarse - superfine X-rude - super fin	Al Ox / Sil Carb Cor. / Carb.sil	Nonwoven (nylon) Non tissé (nylon)	Stainless, aluminum, non ferrous, steels Inox, aciers, aluminium, non ferreux
6260 Ultradisc	X-coarse - extrafine X-rude - extra fin	Aluminum Oxide Corindon	Nonwoven (nylon) Non tissé (nylon)	Stainless, aluminum, non ferrous, steels Inox, aciers, aluminium, non ferreux
6924 siamet hd	X-coarse - Medium X-rude - Moyen	Aluminum Oxide Corindon	Nonwoven (nylon) Non tissé (nylon)	Stainless, non ferrous, steels Inox, aciers non ferreux

Accessories for SCM Discs are shown on Page 75
Les accessoires pour les disques SCM sont disponibles à la page 75



6250 sia SCM						
	Diameter Diamètre	Color Couleur	Grade Grade	Part Number Num produit	Case Caisse	Sleeve Paquet
	4-1/2" (115 mm)	Dark Br. Br foncé	X-coarse X-rude	4460.3298.1922	200	25
		Brown Brun	Coarse Rude	4460.3298.2922	200	25
		Maroon Marron	Medium Moyen	4460.3298.4922	200	25
	5" (125 mm)	Blue Bleu	Very Fiine Très fin	4460.3298.6922	200	25
		Dark Br. Br foncé	X-coarse X-rude	4680.0076.1922	200	25
		Brown Brun	Coarse Rude	4680.0076.2922	200	25
	7" (180 mm)	Maroon Marron	Medium Moyen	4680.0076.4922	200	25
		Blue Bleu	Very Fiine Très fin	4680.0076.6922	200	25
		Dark Br. Br foncé	X-coarse X-rude	5814.0290.1922	100	25
	7" (180 mm)	Brown Brun	Coarse Rude	5814.0290.2922	100	25
		Maroon Marron	Medium Moyen	5814.0290.4922	100	25
		Blue Bleu	Very Fiine Très fin	5814.0290.6922	100	25



6250 sia SCM





Discs SCM Ultradiscs Disques SCM Ultradisques

6260 sia SCM Ultradiscs

	Diameter Diamètre	Color Couleur	Grade Grade	Part Number Num produit	Case Caisse	Sleeve Paquet
	4-1/2" (115 mm)	Dark Br. Br foncé	X-coarse X-rude	4676.1834.1921	200	20
		Brown Brun	Coarse Rude	4676.1834.2921	200	20
		Maroon Marron	Medium Moyen	4676.1834.4921	200	20
		Blue Bleu	Fine Fin	4676.1834.5921	200	20
		Lgt. Blue Bleu pâle	Very fine très fin	4676.1834.6921	200	20
		5" (125 mm)	Dark Br. Br foncé	X-coarse X-rude	4895.8612.1921	200
Brown Brun	Coarse Rude		4895.8612.2921	200	20	
Maroon Marron	Medium Moyen		4895.8612.4921	200	20	
Blue Bleu	Medium Moyen		4895.8612.5921	200	20	
Lgt. Blue Bleu pâle	Very fine très fin		4895.8612.6921	200	20	
7" (180 mm)	Dark Br. Br foncé		X-coarse X-rude	6029.8826.1921	200	20
	Brown Brun	Coarse Rude	6029.8826.2921	200	20	
	Maroon Marron	Medium Moyen	6029.8826.4921	200	20	
	Blue Bleu	Fine Fin	6029.8826.5921	200	20	
	Lgt. Blue Bleu pâle	Very fine très fin	6029.8826.6921	200	20	

Discs SCM Heavy Duty Disques SCM HD

Carbone Fiber discs - Disque en fibre de carbone						
	4-1/2" x 7/8" (115 x 22 mm)	X-Coarse X-Rude			200	20
		Coarse Rude			200	20
	7" x 7/8" (180 x 22 mm)	X-Coarse XRude			50	10
		Coarse Rude			50	10
Hook & loop Discs - Disques auto-agrippants						
	4-1/2" x 7/8" (115 x 22 mm)	X-coarse X-rude			200	25
		Coarse Rude			200	25
		Medium Moyen			200	25
	5" x 7/8" (125 x 22 mm)	X-coarse X-rude			200	25
		Coarse Rude			200	25
		Medium Moyen			200	25
	7" x 7/8" (180 x 22 mm)	X-coarse X-rude			100	25
		Coarse Rude			100	25
		Medium Moyen			100	25



6260 sia SCM Ultradiscs

Pads with protuberance for SCM discs protubérance pour disques SCM

Plateaux avec

5 / 8" - 11		7/8" (22 mm) protuberance	
	Size Dimension	Part Number Num produit	Max RPM
	4-1/2" (115 mm)	0020.7620	8 350
	5" (125 mm)	0020.7621	7 650
	7" (180 mm)	0020.7622	5 350

Pads for SCM Discs - Plateaux pour disques SCM

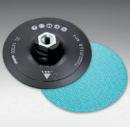
(5/8 - 11)					
	Size Dimension	Hardness Dureté	Max RPM	Part Number Num produit	Sleeve Paquet
	4-1/2" (115 mm)	Soft mou	8 500	0020.2325	2
		Hard Dur	8 500	0020.0180	2
	5" (125 mm)	Hard Dur	7 700	0020.0181	2
	6" (150 mm)	Hard Dur	7 000	0020.0182	2
	7" (180 mm)	Hard Dur	6 500	0020.0183	2

(5/8 - 11)		Big Mushroom - Gros champignon			
	Size Dimension	Hardness Dureté	Max RPM	Part Number Num produit	Sleeve Paquet
	4-1/2" (115 mm)	Hard Dur	8 500	631F.0115	1
	5" (125 mm)	Hard Dur	7 700	632F.0125	1
	7" (180 mm)	Hard Dur	6 500	633F.0180	1

Interface Sponge for Nonwoven Discs (siafast- Big Mushroom) Éponge d'appui pour disques non-tissés (siafast/gros champignon)

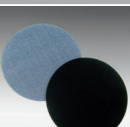
	Size Dimension	Thickness	Max RPM	Part Number Num produit	Sleeve Paquet
	6" (150 mm)	1 mm			1

Series Available for siavlies Discs disponibles pour disques siavlies

Séries

Series Série	Grade Grade	Type of Grit Type de grain	Type of Backing Type de support	Applications Applications
6120 siafleece	Coarse - microfine Rude - micro fin	Al Ox / Sil Carb Cor. / Carb.sil	Nonwoven (nylon) Non tissé (nylon)	Metals Métaux
6140 siavlies	Coarse - microfine Rude - micro fin	Al Ox / Sil Carb Cor. / Carb.sil	Nonwoven (nylon) Non tissé (nylon)	Metals Métaux
6713 siavlies hd	Very fine - microfine Très fin - micro-fin	Silicon Caride Carbure silicium	Nonwoven (nylon) Non tissé (nylon)	Metals Métaux
6913 siavlies hd	Medium - x-fine Moyen - très fin	Aluminum Oxide Corindon	Nonwoven (nylon) Non tissé (nylon)	Metals Métaux
6914 siavlies sd	H-Medium - X-fine H-moyen - très fin	Aluminum Oxide Corindon	Nonwoven (nylon) Non tissé (nylon)	Metals Métaux

siafast Discs siavlies - Disques siafast siavlies

		Aluminum Oxide Corindon			
	6" (150 mm)	Maroon Marron	Very fine Très fin	100	20
		Grey Gris	Ultra fine Ultra fin	100	20
		Yellow Jaune	Micro fine Micro fin	100	20
		Silicone Carbide Carbure silicium			
	6" (150 mm)	Black Noir	Medium Moyen	100	20

		Aluminum Oxide Corindon			
	6" (150 mm) 7 dust holes / trous	Maroon Marron	320	100	20
		Silicone Carbide / Carbure silicium			
	6" (150 mm) 7 dust holes / trous	Grey Gris	100	100	20

		Aluminum Oxide Corindon			
	6" x 1/2" (150 x 12 mm)	Maroon Marron	Coarse Rude	70	7
		Maroon Marron	Medium moyen	70	7
		Maroon Marron	Very fine Très fin	100	20
		Silicone Carbide / Carbure silicium			
	6" x 1/2" (150 x 12 mm)	Grey Gris	Medium Moyen	90	9
		Grey Gris	Very fine Très fin	90	9

6914 siavlies HD		Aluminum Oxide Corindon				
	Dia. Dia.	Color Couleur	Grit Grain	Part Number Num produit	Case Caisse	Sleeve Paquet
	6" x 1/2" (150 x 12 mm)	Maroon Marron	HeavyMed. Moy.fort	2073.6558.3911	70	7
		Maroon Marron	Medium moyen	2073.6558.4911	60	6
		Maroon Marron	Very fine Très fin	2073.6558.6911	90	9

Series Available siafix Nonwoven discs ries disponibles pour disques siafix non tissé

Sé-

Series Série	Grade Grade	Type of Grit Type de grain	Type of Backing Type de support	Applications Applications
6250 SCM	X-coarse - s-fine X-rude - s-fin	Al Ox / Sil Carb Cor. / Carb.sil	Nonwoven (nylon) Non tissé (nylon)	Steels, Stainless, aluminum Aciers, inox, aluminium
6924 siamet HD	X-coarse - Med X-rude - moyen	Aluminum Oxide Corindon	Nonwoven (nylon) Non tissé (nylon)	Non alloy & high allow steels Aciers non alliés ou fortement alliés
6300 siastrip	Extra coarse Extra rude	Al Ox / Sil Carb Cor. / Carb.sil	Nonwoven (nylon) Non tissé (nylon)	Steel, stainless steel, aluminum Acier, acier inoxydable, aluminium
sia spectrum	Medium - V-fine Moyen - très fin	Al Ox / Sil Carb Cor. / Carb.sil	Nonwoven (nylon) Non tissé (nylon)	Metal, Métaux

Nonwoven siafix discs - Disques non tissés SCM siafix



6924 siamet HD					r-loc	s-loc m
	Dia. Dia.	Grade Grade	Case Caisse	Sleeve Paquet	P. Number N. produit	P. Number N. produit
	2" (50 mm)	X-Coarse X-Rude	300	50	0546.3989.1923	2956.8143.1923
		Coarse Rude	300	50	0546.3989.2923	2956.8143.2923
		Medium Moyen	300	50	0546.3989.4923	2956.8143.4923
	3" (75 mm)	X-Coarse X-Rude	100	25	1073.9713.1923	3506.0088.1923
		Coarse Rude	100	25	1073.9713.2923	3506.0088.2923
		Medium Moyen	100	25	1073.9713.4923	3506.0088.4923

6250 sia SCM					r-loc	s-loc m
	Dia. Dia.	Grade Grade	Case Caisse	Sleeve Paquet	P. Number N. produit	P. Number N. produit
	2" (50 mm)	X-Coarse X-Rude	300	50	5903.6105.1922	8314.0259.1922
		Coarse Rude	300	50	5903.6105.2922	8314.0259.2922
	2" (50 mm)	Medium Moyen	300	50	5903.6105.4922	8314.0259.4922
		Veryfine Très fin	300	50	5903.6105.6922	8314.0259.6922
		Superfine Super fin	300	50	1416.5100.7714	8314.0259.7714
		X-Coarse X-Rude	100	25	6452.8050.1922	8863.2204.1922
	3" (75 mm)	Coarse Rude	100	25	6452.8050.2922	8863.2204.2922
		Medium Moyen	100	25	6452.8050.4922	8863.2204.4922
		Veryfine Très fin	100	25	6452.8050.6922	8863.2204.6922
		Superfine Super fin	300	50	1965.7045.7714	8863.2204.7714
		X-Coarse X-Rude	100	25	6452.8050.1922	8863.2204.1922

HOLDERS - Supports



siafix Holder Support siafix					r-loc	s-loc m
	Dia. Dia.	Grade Grade	Case Caisse	Sleeve Paquet	P. Number N. produit	P. Number N. produit
	3/4" (20 mm)	Medium Moyen	5	1	0020.8063.01	0020.8072.01
	1" (25 mm)	Medium Moyen	5	1	0020.8064.01	0020.8073.01
	1-1/2" (38 mm)	Medium Moyen	5	1	0020.8065.01	0020.8074.01
	2" (50 mm)	Soft Mou	5	1	0020.8067.01	0020.8076.01
		Medium Moyen	5	1	0020.8066.01	0020.8075.01
		Hard Dur	5	1	0020.8068.01	0020.8077.01
	3" (75 mm)	Soft Mou	5	1	0020.8070.01	0020.8079.01
		Medium Moyen	5	1	0020.8069.01	0020.8078.01
		Hard Dur	5	1	0020.8071.01	0020.8080.01

Spectrum Unitized Wheels Roues «unitized» Spectrum					r-loc
	Dia. Dia.	Grade Grade	Colour Couleur	Sleeve Paquet	P. Number N. produit
	2" (50 mm)	Medium Moyen	Red Rouge	60	5999.2104
		Fine Fin	Grey Gris	60	5999.2103
	2" (50 mm)	Extrafine Extra fin	Blue Bleu	60	5999.2102
		Very Fine Très fin	Green Vert	60	5999.2101
	3" (75 mm)	Medium Moyen	Red Rouge	20	5999.2109
		Fine Fin	Grey Gris	20	5999.2108
	3" (75 mm)	Extrafine Extra fin	Blue Bleu	20	5999.2107
		Very Fine Très fin	Green Vert	52	5999.2106

Spectrum Unitized Wheels Meules compacts «unitized»

Spectrum Unitized Wheels Roues «unitized» Spectrum						
	Dia. Dia.	Colour Coul.	Application	Max RPM	Case Caisse	P. Number N. produit
	3" x 1/4" x 1/4" (76 x 6 x 6 mm)	Red Rouge	Removal Dégrossir	18 000	20	5999.2080
		Grey Gris	Blending Lissage	18 000	20	5999.2079
		Blue Bleu	Finishing Finition	18 000	20	5999.2078
	6" x 1/4" x 7/8" (76 x 6 x 22 mm)	Green Vert	Polishing Polissage	12 000	20	5999.2077
		Red Rouge	Removal Dégrossir	6 000	8	5999.2168
	6" x 1/4" x 7/8" (76 x 6 x 22 mm)	Grey Gris	Blending Lissage	6 000	8	5999.2169
		Blue Bleu	Finishing Finition	6 000	8	5999.2129
		Green Vert	Polishing Polissage	4 700	8	5999.2128
	6" x 1/2" x 7/8" (76 x 12 x 22 mm)	Red Rouge	Removal Dégrossir	6 000	6	5999.2192
		Grey Gris	Blending Lissage	6 000	6	5999.2193
		Blue Bleu	Finishing Finition	6 000	6	5999.2194
		Green Vert	Polishing Polissage	4 700	6	5999.2195

siastrip Discs Disques siastrip

6300 siastrip	siafix Discs Disques siafix				r-loc	s-loc m
	Dia. Dia.	Grade	Case Caisse	Sleeve Paquet	P. Number N. produit	P. Number N. produit
	2" (50 mm)	x-Coarse x-Rude	100	10	1715.2309.1721	8612.7001.1721
	3" (75 mm)	x-Coarse x-Rude	100	10	2242.7566.1721	9140.2725.1721

4560 X-LOCK	6300 siastrip Discs Disques 6300 siastrip				
	Diameter Diamètre	Grade	Part Number No. produit	Case Caisse	Sleeve Paquet
	4-1/2" x 7/8" (115 x 22 mm)	x-coarse x-rude	0423.4783.1721		10
	5" x 7/8" (125 x 22 mm)	x-coarse x-rude	0643.1561.1721		10

Flap Discs COMBI - Disques à lamelles COMBI

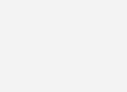
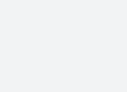
Flap Discs COMBI Disques à lamelles COMBI					
	Dia. Dia.	Grade	Part Number Num produit	RPM*	Sleeve Paquet
	4-1/2" x 7/8" (115 x 22,3 mm)	Ultra Coarse Ultra rude	0021.C005	5 - 6K	10
		X-coarse X-rude	0021.C004	5 - 6K	10
	5" x 7/8" (125 x 22,3 mm)	Coarse Rude	0021.C003	5 - 6K	10
		Medium Moyen	0021.C002	5 - 6K	10
		Veryfine Très fin	0021.C001	5 - 6K	10
		Ultra Coarse Ultra rude	0021.C010	5 - 6K	10
		X-coarse X-rude	0021.C009	5 - 6K	10
	5" x 7/8" (125 x 22,3 mm)	Coarse Rude	0021.C008	5 - 6K	10
		Medium Moyen	0021.C007	5 - 6K	10
		Veryfine Très fin	0021.C006	5 - 6K	10

* Recommended speed - Vitesse recommandée



Unitized Wheels - Meules compactes "unitized"

Unitized Wheels Meules "unitized" compactes				
	4-1/2" x 7/8" 115 x 22,3 mm	Medium Moyen	5 - 6K	10
		Soft Souple	5 - 6K	10
	5" x 7/8" 125 x 22,3 mm	Medium Moyen	5 - 6K	10
		Soft Souple	5 - 6K	10

* Recommended speed - Vitesse recommandée

Available in a wide range of different shapes and dimensions with different grit types and densities

Disponible dans un grand nombre de formes et de dimensions, diverses granulométries et densités



Felt Wheels - Roues en feutre

To Use with Your Preferred Compounds Utilisez-les avec vos pâtes abrasives préférées				
	Diameter Diamètre	Part Number No produit	Rec. speed Vitesse rec.	Sleeve Paquet
	4-1/2" x 7/8" (115 x 22,3 mm)	0021.C015	4500 RPM	5
		0021.C016	3000 RPM	5

Nonwoven Spindle Mounted Flap Wheels
Meules sur support non-tissé montées en fuseau

6120
siavlies

Size, specifications and prices are available upon request

Les grandeurs, les spécifications et les prix de ces roues sont disponibles sur demande



siamop Abrasive Wheels siamop (keeway)

Roues à poncer

2988 Coated siamop 2988 Flexible siamop

	Grit Grain	Part Number No produit	Rec. speed Vitesse rec.	Sleeve Paquet
	40	0020.9041	2 800 RPM	1
	60	0020.9042	2 800 RPM	1
	80	0020.9043	2 800 RPM	1
105 x 100 x 19 mm	120	0020.9044	2 800 RPM	1
	180	0220.9045	2 800 RPM	1

Optimal performance

2988 is a specially optimized series for siamop due to the backing, which breaks down evenly with the grits to give a longer lasting product with a consistent surface finish

Performance optimal

2988 est une série spécialement optimisée pour siamop en raison du support, qui se décompose uniformément avec les grains pour donner un produit plus durable avec une finition de surface uniforme

For various applications

- Deburring
- Discolouration removal
- Masking of metal surfaces

Pour des applications variées

- Ébavurage
- Décoloration
- Masquage des surfaces métalliques

	Coarse / 40 Grossier / 40		2 800 RPM	1
	Medium / 60 Moyen / 60		2 800 RPM	1
	Fine / 120 Fin / 120		2 800 RPM	1
105 x 100 x 19 mm	Very Fine / 180 Très Fin / 180		2 800 RPM	1

Long lifetime

Interleaved siamop combines the advantages of 2988 coated serie and 6130 Heavy Duty which is a longer lasting nonwoven series containing approximately 25% more fibres, resin and abrasives compared to 6120

Meilleure durée de vie

Siamop mixte combine les avantages de la série 2988 et 6130 Heavy Duty qui est une série non tissée performante contenant environ 25% plus de fibres, de résine et d'abrasifs par rapport à 6120

For various applications

- Weld cleaning
- Satin Finishing

Pour des applications variées

- Nettoyage de soudure
- Fini satin

	Coarse Grossier		2 800 RPM	1
	Medium Moyen		2 800 RPM	1
	Fine Fin		2 800 RPM	1
105 x 100 x 19 mm	Very Fine Très Fin		2 800 RPM	1
	Medium Moyen		2 800 RPM	1

6130 Heavy Duty has a three dimensional structure and highly conformable nylon fibres making the product ideal for decorative and satin finishing

6130 Heavy Duty a une structure tridimensionnelle et des fibres de nylon hautement conformes rendant le produit idéal pour la finition décorative et satinée

- Light deburring
- Pre Polishing
- Oxidation removal

Pour des applications variées

- Ébavurage léger
- Pré-polissage
- Enlèvement de l'oxydation

FOAM ABRASIVES ABRASIFS SUR MOUSSE



Foam Abrasives Series nibles pour les abrasifs en mousse

Séries dispo-

Thickness Épaisseur	siasponge Series Série siasponge		Grade	Form Forme
3/16" (5 mm)	7979	FLAT Pads (PU - WET) Tampon mince (PU - à l'eau)	medium - microfine moyen - micro fin	Pads & Discs Tampons & disques
1/2" (13 mm)	7983	FLEX Pads Tampon Flexible	medium - ultra fine moyen - ultra fin	Pads & Discs Tampons & disques
1" (26 mm)	7990	HARD Block Bloc DUR	coarse - super fine rude - super fin	Blocks Blocs
	7991	SOFT Block Bloc SOUPLE	medium - ultra fine moyen - ultra fin	

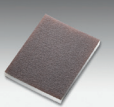
79 siasponge		Standard Pads			
	Size Dimension	Grade Grade	P. Number N. produit	Case Caisse	Sleeve Paquet
	3-3/4" x 4-3/4" (95 x 120 mm) Thickness: 1/2" Épaisseur: 12 mm	Medium Moyen	0070.0480	250	
		Fine Fin	0070.0468		
		Super fine Super fin	0070.0469		
			0070.0473		



"FLAT" Pad - Tampon "MINCE"

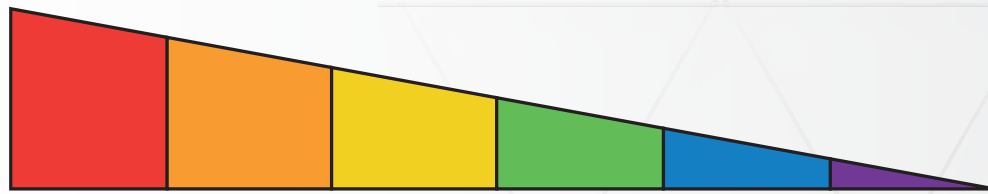
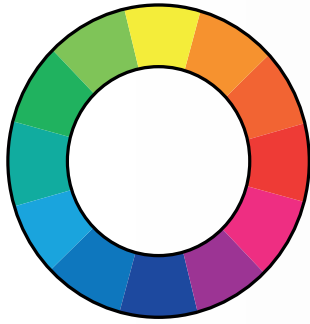

Coarse medium fine super fine ultra fine micro fine
 Grossier moyen fin super fin ultra fin micro fin

7979 siasponge		FLAT Pad (PU) WET Tampon MINCE (PU) à l'EAU				
	Size Dimension	Color Couleur	Grade Grade	P. Number N. produit	Quantity / Masterpack* Quantité / Carton maître	Qty / Envelope Qté / Enveloppe
	4-1/2" x 5-1/2" (115 x 140 mm)	Orange Orange	Medium Moyen	0070.1603.01	8	20
		Yellow Jaune	Fine Fin	0070.1602.01	8	20
		Green Vert	Super fine Super fin	0070.1605.01	8	20
		Blue Bleu	Ultra fine Ultra fine	0070.1606.01	8	20
		Violet Violet	Micro fine Micro fin	0070.1604.01	8	20
		Bulk - Vrac				
	4-1/2" x 5-1/2" (115 x 140 mm) Thickness: 3/16" Épaisseur: 5 mm	Orange Orange	Medium Moyen	0070.1603.02	250 / case	
		Yellow Jaune	Fine Fin	0070.1602.02	250 / case	
		Green Vert	Super fine Super fin	0070.1605.02	250 / case	
		Blue Bleu	Ultra fine Ultra fine	0070.1606.02	250 / case	
		Violet Violet	Micro fine Micro fin	0070.1604.02	250 / case	

7972 siasponge		SOFT Pad (EVA) DRY Tampon SOUPLE (EVA) à SEC				
	Size Dimension	Color Couleur	Grade Grade	P. Number N. produit	Case Caisse	Sleeve Paquet
	3" x 4" (75 x 102 mm) Épaisseur: 3/16"	Orange Orange	Medium Moyen	0070.1391.01	720	30
		Yellow Jaune	Fine Fin	0070.1392.01	720	30
		Blue Bleu	Ultra fine Ultra fine	0070.1394.01	720	30
		Violet Violet	Micro fine Micro fin	0070.1395.01	720	30
	3" x 4-3/8" (75 x 110 mm) Épaisseur: 3/16"	Orange Orange	Medium Moyen	0070.1404.01	600	50
		Blue Bleu	Ultra fine Ultra fine	0070.1402.01	600	50
		Violet Violet	Micro fine Micro fin	0070.1408.01	600	50

		SOFT Pad (PU) Tampon SOUPLE (PU) à				
	Size Dimension	Color Couleur	Grade Grade	P. Number N. produit	Case Caisse	Sleeve Paquet
	3" x 4" (75 x 102 mm)	Green Vert	Super fine Super fin		720	30
		Yellow Jaune	Fine Fin		600	50
	3" x 4-3/8" (75 x 110 mm) Thickness: 3/16" Épaisseur: 5 mm	Green Vert	Super fine Super fin		600	50

7979 siasponge		SOFT Pad (PU) WET Tampon SOUPLE (PU) à l'EAU				
	Size Dimension	Color Couleur	Grade Grade	P. Number N. produit	Case Caisse	Sleeve Paquet
	6" (150mm) 15 holes / trous	Orange Orange	Medium Moyen	0070.1598.01	240	20
		Yellow Jaune	Fine Fin	0070.1597.01	240	20
		Green Vert	Super fine Super fin	0070.1600.01	240	20
		Blue Bleu	Ultra fine Ultra fine	0070.1601.01	240	20
		Violet Violet	Micro fine Micro fin	0070.1599.01	240	20

"FLEX" Pad - Tampon "FLEXIBLE"

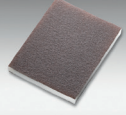

7983-CP siasponge		Standard FLEX Pads			
	Size Dimension	Grade Grade	P. Number N. produit	Case Caisse	Sleeve Paquet
	3-3/4" x 4-3/4" (98 x 120 mm) Thickness: 1/2" Épaisseur: 12 mm	Medium	0070.0468	250	
		Fine	0070.0469	250	

7983 siasponge		FLEX Pad Tampon FLEXIBLE				
	Size Dimension	Color Couleur	Grade Grade	P. Number N. produit	Quantity / Masterpack* Quantité / Carton maître	Qty / Envelope Qté / Enveloppe
	4" x 4-1/2" (98 x 120 mm)	Orange Orange	Medium Moyen	0070.1244.01	24	10
		Yellow Jaune	Fine Fin	0070.1247.01	24	10
		Green Vert	Super fine Super fin	0070.1232.01	24	10
		Blue Bleu	Ultra fine Ultra fine	0070.1243.01	24	10
Bulk - Vrac					Quantit Quantité	
	4" x 4-1/2" (98 x 120 mm) Thickness: 1/2" Épaisseur: 13 mm	Orange Orange	Medium Moyen	0070.1244.02	250 / case	
		Yellow Jaune	Fine Fin	0070.1247.02	250 / case	
		Green Vert	Super fine Super fin	0070.1232.02	250 / case	
		Blue Bleu	Ultra fine Ultra fine	0070.1243.02	250 / case	

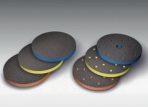

siafast "FLEX" Pad - Tampon "FLEXIBLE" siafast

7983 siasponge		FLEX Pad Tampon FLEXIBLE				
	Size Dimension	Color Couleur	Grade Grade	P. Number N. produit	Case Caisse	Sleeve Paquet
	3" x 4" (75 x 102 mm)	Orange Orange	Medium Moyen	0070.1396.01	264	22
		Yellow Jaune	Fine Fin	0070.1397.01	264	22
		Green Vert	Super fine Super fin	0070.1398.01	264	22
		Blue Bleu	Ultra fine Ultra fine	0070.1399.01	264	22
	3" x 4-3/8" (75 x 110 mm) Thickness: 1/2" Épaisseur: 13 mm	Orange Orange	Medium Moyen	0070.1409.01	264	22
		Yellow Jaune	Fine Fin	0070.1410.01	264	22
		Green Vert	Super fine Super fin	0070.1411.01	264	22
		Blue Bleu	Ultra fine Ultra fine	0070.1412.01	264	22

7983 siasponge		FLEX Pad Tampon FLEXIBLE				
	Size Dimension	Color Couleur	Grade Grade	P. Number N. produit	Case Caisse	Sleeve Paquet
	6" (150 mm) No hole sans trou	Orange Orange	Medium Moyen	0070.1250.01	80	10
		Yellow Jaune	Fine Fin	0070.1251.01	80	10
		Blue Bleu	Ultra fine Ultra fine	0070.1249.01	80	10
	6" (150 mm) 15 holes / trous	Orange Orange	Medium Moyen	0070.1235.01	80	10
		Yellow Jaune	Fine Fin	0070.1234.01	80	10
		Blue Bleu	Ultra fine Ultra fine	0070.1252.01	80	10

Thickness: 3/16"
Épaisseur: 5 mm

«HARD» block - Bloc «DUR»

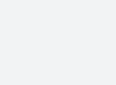
7990 siasponge		HARD Block Bloc DUR				
	Size Dimension	Color Couleur	Grade Grade	P. Number N. produit	Case Caisse	Sleeve Paquet
	2-3/4" x 4" (69 x 98 mm)	Red Rouge	Coarse Rude	0070.1256.01	28	10
		Orange Orange	Medium Moyen	0070.1242.01	28	10
		Yellow Jaune	Fine Fin	0070.1233.01	28	10
		Green Vert	Superfine Super fin	0070.1241.01	28	10
Bulk - Vrac					Quantit Quantité	
	2-3/4" x 4" (69 x 98 mm)	Red Rouge	Coarse Rude	0070.1256.02	120 / case	
		Orange Orange	Medium Moyen	0070.1242.02	120 / case	
		Yellow Jaune	Fine Fin	0070.1233.02	120 / case	
		Green Vert	Superfine Super fin	0070.1241.02	120 / case	
Thickness: 1" Épaisseur: 26 mm						

Bulk case of 250 blocks also available upon request
Caisse de 250 blocs en vrac aussi disponible sur demande

«SOFT» Block - Bloc «SOUPLE»

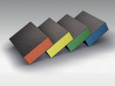
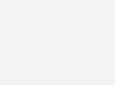
7991 siasponge		SOFT Block Bloc SOUPLE				
	Size Dimension	Color Couleur	Grade Grade	P. Number N. produit	Case Caisse	Sleeve Paquet
	2-3/4" x 4" (69 x 98 mm)	Orange Orange	Medium Moyen	0070.1254.01	28	10
		Yellow Jaune	Fine Fin	0070.1228.01	28	10
		Green Vert	Superfine Super fin	0070.1253.01	28	10
		Blue Bleu	Ultrafine Ultra fine	0070.1260.01	28	10
Bulk - Vrac					Quantit Quantité	
	2-3/4" x 4" (69 x 98 mm)	Orange Orange	Medium Moyen	0070.1254.02	120 / case	
		Yellow Jaune	Fine Fin	0070.1228.02	120 / case	
		Green Vert	Superfine Super fin	0070.1253.02	120 / case	
		Blue Bleu	Ultrafine Ultra fine	0070.1260.02	120 / case	
Thickness: 1" Épaisseur: 26 mm						

Bulk case of 250 blocks also available upon request
Caisse de 250 blocs en vrac aussi disponible sur demande

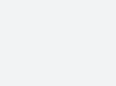
7990 siasponge		HARD Angled Block Bloc DUR avec angles				
	Size Dimension	Color Couleur	Grade Grade	P. Number N. produit	Case Caisse	Sleeve Paquet
	2-3/4" x 4" (69 x 98 mm)	Orange Orange	Medium Moyen	0070.1255.01	28	10
		Yellow Jaune	Fine Fin	0070.1230.01	28	10
		Green Vert	Superfine Super fin	0070.1351.01	28	10
Big Box - grosse boîte					Quantit Quantité	
	2-3/4" x 4" (69 x 98 mm)	Orange Orange	Medium Moyen	0070.1255.02	120	
		Yellow Jaune	Fine Fin	0070.1230.02	120	
Thickness: 1" Épaisseur: 26 mm						

Bulk case of 250 blocks also available upon request
Caisse de 250 blocs en vrac aussi disponible sur demande



7990 siasponge

Pad for Foam Discs - Plateaux pour disques en mousse

6" (150 mm)	No hole / sans trou	
	Hardness Dureté	Part Number Num produit
	Medium Moyen	0020.0345
	Fastener Attache	5 / 16"
	Max. RPM	12 000 RPM

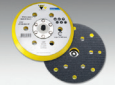
6" (150 mm)	15 holes / 15 trous	
	Hardness Dureté	Part Number Num produit
	Soft Mou	0020.4740
	Fastener Attache	5 / 16"
	Max. RPM	10 000 RPM



MICRO & SUPER ABRASIVES
(FILM PRODUCTS)

MICRO & SUPER ABRASIFS
(PRODUITS SUR FILM)



Micro & Super Abrasives Film Products Produits micro & super abrasifs sur film



- Diamond superabrasives slurry coated on high precision polyester film
- Super-abrasif diamanté avec distribution étalée sur film de polyester haute précision

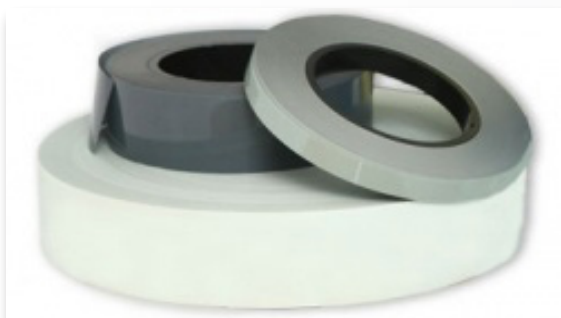

Microfinishing Film (FA50, FS50, FA35)

- Microabrasives electrostatic coating on high precision polyester film
- Micro-abrasif avec distribution électrostatique sur film de polyester haute précision



- Microabrasives slurry coated on high precision polyester film
- Micro-abrasif avec distribution étalée sur film de polyester haute précision



Microfinishing Film Final (FA91)

- Polishing microabrasives coated on a soft flocked film
- Micro-abrasif de finition et polissage étalé sur film floqué



Polishing Flocked Film (FA92, FS92, FE92)

- Microabrasives coated on a soft flocked polyester film
- Micro-abrasif de finition et polissage étalé sur film souple floqué

Polishing Film: Slurry Coated

Film Polissage : épandage par badigeonnage

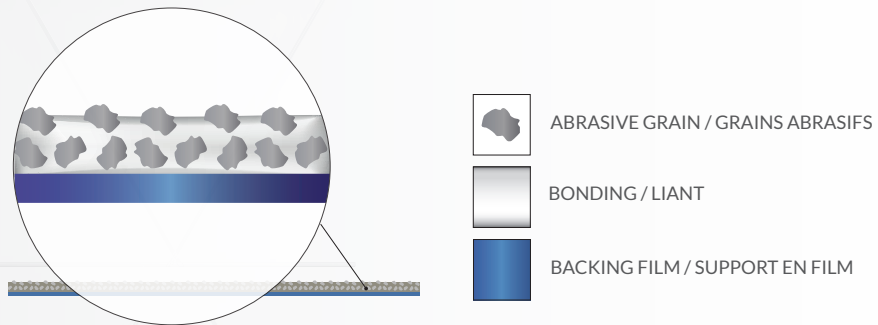

Grit Range - Granulométrie

FD30		FA30		FS30	
µm	FEPA-P	µm	FEPA-P	µm	FEPA-P
80	180	60	240	40	360
60	240	40	360	30	500
45	320	30	500	20	800
30	500	20	800	16	1200
15	1200	16	1200	9	2000
9	2000	12	1500	5	2700
5	2700	9	2000	3	3000
3	3000	5	2700	1	6000
1	6000	3	3000		
0,5	9000	2	5000		
		1	6000		

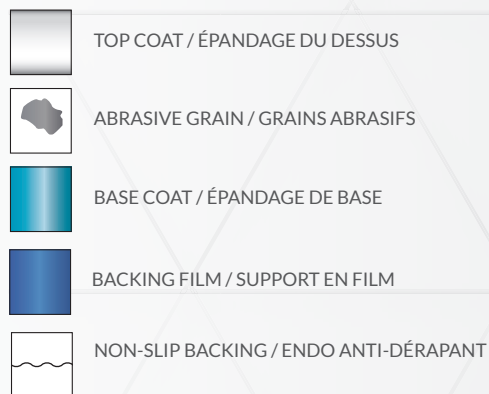
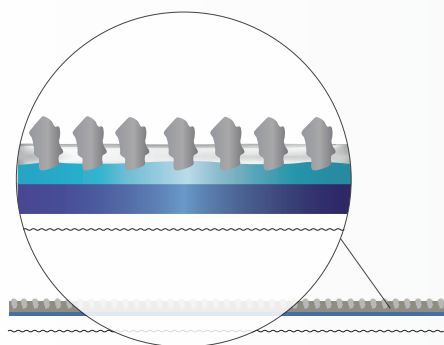

Series Série	Grit Range Granulométrie	Backing Thickness Épaisseur du support	Special Spécial	Type of Grit Type de grain	Forms Formes
FA50 (ASS)	150 - 2700 100 - 5 µm	125 µm (5 mil.)	Electrostatic Électrostatique	Alum. Oxide Corindon	Rolls, sheets, discs, belts Rouleaux, feuilles, disques, bandes
FS50 (ASS)	240 - 2000 60 - 9 µm	125 µm (5 mil.)	Electrostatic Électrostatique	Silicon Carb. Carb. Silicium	Rolls, sheets, discs, belts Rouleaux, feuilles, disques, bandes
FA35	240 - 2000 60 - 9 µm	74 µm (3 mil.)	Electrostatic Électrostatique	Alum. Oxide Corindon	Rolls, sheets, discs, belts Rouleaux, feuilles, disques, bandes

ASS = Antislip backing / Endo anti-dérapant

Price available upon request
Prix disponible sur demande

Grit Range - Granulométrie

FA50		FS50		FA35	
µm	FEPA-P	µm	FEPA-P	µm	FEPA-P
100	150	60	240	60	240
80	180	40	360	40	360
60	240	30	500	30	500
50	280	20	800	20	800
40	360	15	1200	15	1200
30	500	9	2000	9	2000
20	800				
15	1200				
12	1500				
9	2000				
5	2700				

Microfinishing Final Film: Coated on Soft Flocked Film

Film microfinition finale: épannage sur film souple floqué

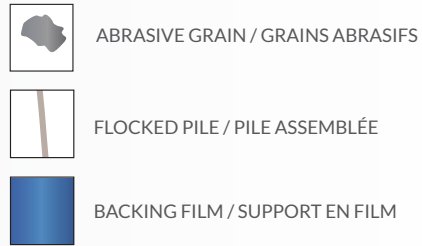
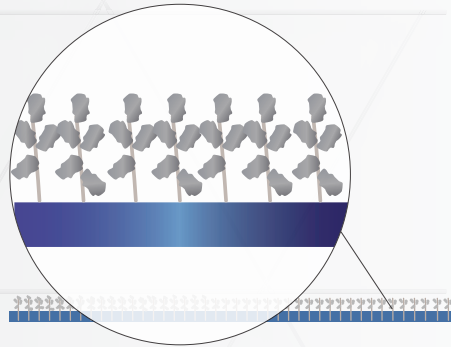

Serie Série	Grit Range Granulométrie	Backing Thickness Épaisseur du support	Special Spécial	Type of Grit Type de grain	Forms Formes
FA92 (ASS)	1200 - 6000 16 - 1 μm	75 μm (3 mil.)	Flocked Film Film floqué	Alum. Oxide Corindon	Rolls, discs Rouleaux, disques
FS92* (ASS)	3000 - 12000 3 - 0,3 μm	75 μm (5 mil.)	Flocked Film Film floqué	Silicon Carb. Carb. Silicium	Rolls, discs Rouleaux, disques
FE92*	6000 - 9000 1 - 0,5 μm	75 μm (5 mil.)	Flocked Film Film floqué	Cerium Oxide Oxyde cérium	Rolls, discs Rouleaux, disques

*Available upon special request
*Disponible sur demande spéciale

Grit Range - Granulométrie

FA91		FA92		FS92		FE92	
μm	FEPA-P	μm	FEPA-P	μm	FEPA-P	μm	FEPA-P
1	6000	5	2700	3	3000	1	6000
0,5	9000	2	5000	0,3	12000	0,5	9000

Application Guide for Micro & Super Abrasives Film Products

Guide d'application des produits micro & super abrasifs sur film

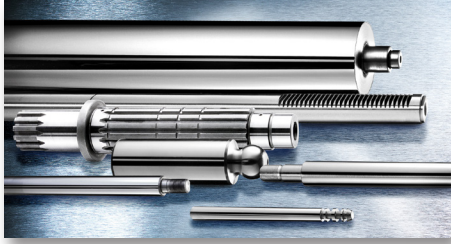

	Diamond Polishing Polissage diamant		Polishing Polissage		Microfinishing Microfinition		Microfinishing Final Microfinition Final		Polishing Flocked Film Polissage - film floqué	
	FD30	FA30	FS30	FA50	FS50	FA35	FA91	FA92	FS92	FE92
Hydraulic / hydraulique		x		x		x				
Pneumatic / pneumatique	x	x	x				x	x	x	
Cylindre	x	x	x	x	x	x	x	x	x	
Photogravure / photogravure			x	x		x				

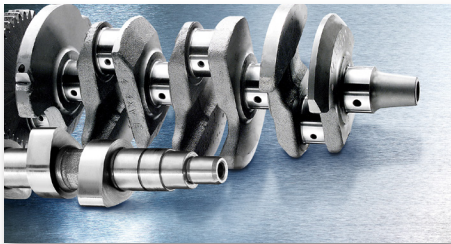

	FD30	FA30	FS30	FA50	FS50	FA35	FA91	FA92	FS92	FE92
Camshaft / arbre à came				x						
Steering Rack / direction		x		x		x				
Motor Part / pièce moteur	x	x	x	x	x	x				
Valve / soupape		x		x		x				
Crankshaft / vilebrequin				x						
Shock Absorber / Amortisseur				x		x				
Gear / engrenage		x		x		x				
Precision Part / pièce précision	x	x	x	x	x	x				



Jewellery - Bijouterie

	FD30	FA30	FS30	FA50	FS50	FA35	FA91	FA92	FS92	FE92
case / boîtier	x	x	x			x			x	x
bracelet										



Metallurgy - Métallurgie

	FD30	FA30	FS30	FA50	FS50	FA35	FA91	FA92	FS92	FE92
Copper / cuivre		x		x		x	x	x	x	
Chrome	x	x		x		x	x	x	x	
Steel / acier		x	x	x	x	x	x	x	x	
Cast iron / fonte	x	x		x						
Zinc	x									
Hard steel / acier trempé	x						x			
Carbide / carbure	x						x			
Aluminum / aluminium		x	x	x	x	x				
Rubber / caoutchouc	x	x	x	x	x	x				
Teflon / téflon			x	x	x	x				

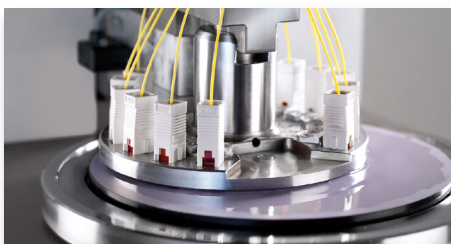

	FD30	FA30	FS30	FA50	FS50	FA35	FA91	FA92	FS92	FE92
Optic Fiber / fibre optique	x	x	x					x	x	x
Hard disc / disque dur	x	x	x							
Micromotor / micromoteur	x	x								
Magnetic Head / tête magn.	x	x								
Opt. connector / con. optique		x		x						
CD Restoring / restauration CD		x	x							

The image features a close-up, low-angle view of several wooden profiles. The profiles are arranged in a way that creates a sense of depth and perspective. The wood grain is clearly visible, and the profiles have a distinct, fine-grained texture, likely from a sanding process. The lighting is dramatic, highlighting the edges and the texture of the wood. A dark, semi-transparent maroon banner is overlaid across the middle of the image, containing the text in white.

PROFILE SANDING PONÇAGE DE PROFIL

Selection Guide of Abrasives for Profile Sanding

Guide de sélection d'abrasifs pour les profils

Series Série	Grit Range Granulométrie	Type of Grit Type de grain	Type of Backing Type de support	Applications Applications
2933 siatur jo	60 - 220	Aluminum Ox. Corindon	JO-Cloth Toile-jo	Resinous woods, curve & profiles Bois tendre et résineux, courbes & profils
2936 siatur jj	60 - 320	Aluminum Ox. Corindon	JJ-Cloth Toile-jj	Woods, curve & profiles Bois, courbes & profils
2943 siatur h	80 - 240	Aluminum Ox. Corindon	H-Cloth Toile-h	Soft woods, MDF, curve & profiles Bois tendre, MDF, courbes & profils
2951 siatur h	40 - 600	Aluminum Ox. Corindon	H-Cloth Toile-h	Varnishes, curves & profiles Entre couche de vernis, profils

Profile Sanding Set

Ensemble de ponçage de profil

2943 siatur h	Aluminum oxide (h-cloth) - corindon (toile-h)			
	Size Dimension	Grit Grain	Part Number Numéro de produit	Qty / sleeve Qté / paquet
	26" x 39-1/2" (660 x 1000 mm)	080 - 240	0779.9568.xxxx	2
Grit / Grain: 80, 100, 120, 150, 180, 240				

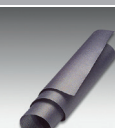
siaklett	Self Aggripping Sheets Feuilles autoagrippantes			
	Size Dimension	Grit Grain	Part Number Numéro de produit	Qty / sleeve Qté / paquet
	27-1/2" x 19-1/2" (700 x 500 mm)		5797.3499	5
	27-1/2" x 39-3/4" (700 x 1000 mm)		6640.4283	5

Balco #67	Contact Glue - Colle contact			
	Size Dimension	Grit Grain	Part Number Numéro de produit	Qty / sleeve Qté / paquet
	15 oz. (425 g)		0020.0379	1

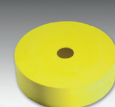
Pro-Core	Wheels for Profile - Roues pour profil			
	Size Dimension	Thickness Épaisseur	Part Number Numéro de produit	Qty / sleeve Qté / paquet
	7" x 1-1/4" (180 x 32 mm)	2" (50 mm)	0020.0377	1



Standard Pattern for Vonnegut Wheels Patron standard pour les roues Vonnegut

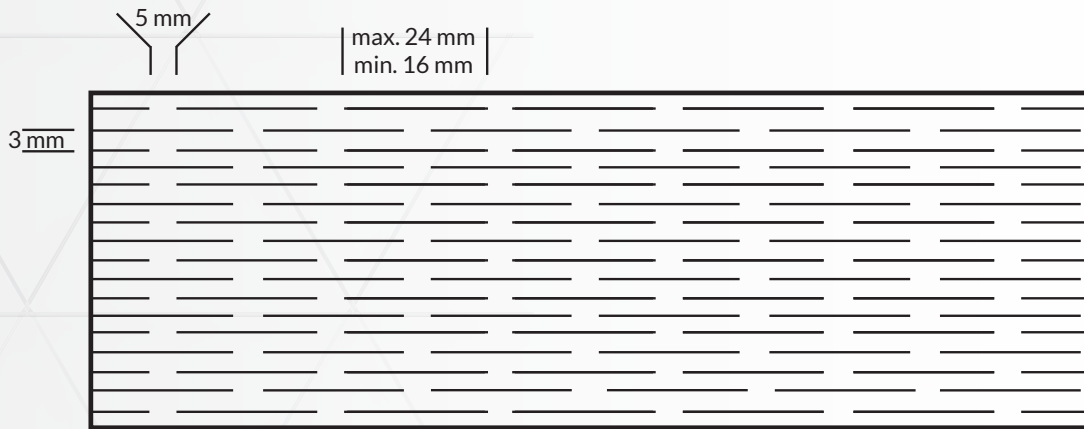

➔ Other patterns available upon request
D'autres patrons disponibles sur demande

Cloth Rolls for Vonnegut Wheels Rouleaux de toile abrasive pour roues Vonnegut

2933 siatur jo	Aluminum Oxide (jo-cloth) - Corindon (toile-jo)				
	Size Dimension	Grit Grain	Part Number Numéro de produit	Qty / case Qté / caisse	Qty / sleeve Qté / paquet
	4" x 55 yds (100 x 50 m)	60 - 220	5611.8791.xxxx		1
	6" x 55 yds (150 x 50 mm)	60 - 220	4140.6699.xxxx		1

Grit / Grain: 60, 80, 100, 120, 150, 180, 220

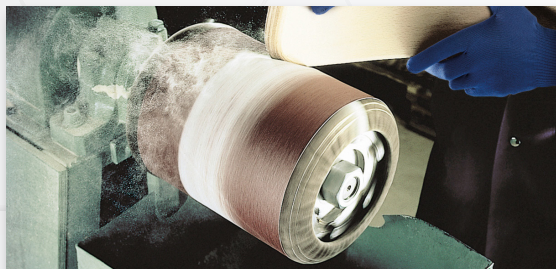

Flexible Belts for Sleeves & Narrow Belts are shown on pages 27

Bandes flexibles pour ballons et bandes étroites sont disponibles aux page 27



Rolls with Flexible Cloth are shown on page 34

Rouleaux avec toile flexible disponibles à la page 34

The image features a central purple banner with white text. Above and below the banner are close-up photographs of sanding brush broom heads. The brooms have light-colored, natural fiber bristles and are mounted on dark green or black handles. Some handles have yellow tape at the base. In the bottom foreground, a large, circular, grey sanding disc is visible, partially overlapping the lower part of the brooms. The disc has a white label with blue and black text.

SANDING BRUSH BROSSES POUR PONÇAGE

PRO-FLEX
Made in Denmark - Max. umbr / m 1500

Model

Karr

Proflex Brushes - Brosses Proflex



Aluminum Oxide (cloth) - Corindon (toile)

	Size Dimension	Thickness Épaisseur	Shaft Tige	Grit Grain	Part Number Numéro de produit	Qty / sleeve Qté / paquet
	8" (200 mm)	2" (50 mm)	3/8" (10 mm)	040 - 400	030P.4579	1
	Size Dimension	Thickness Épaisseur	Bore Trou	Grit Grain	Part Number Numéro de produit	Qty / sleeve Qté / paquet
	9-1/2" (250 mm)	2" (50 mm)	1-1/4" (30 mm)	040 - 320	030P.6825	1
			2" (50 mm)	040 - 320	030P.2449	1
	4" (100 mm)	1-1/4" (30 mm)	040 - 320	030P.5519	1	
		2" (50 mm)	040 - 220	030P.5798	1	
12-1/2" (320 mm)	4" (100 mm)	1-1/4" (30 mm)	040 - 320	030P.3667	1	
		2" (50 mm)	040 - 320	030P.9972	1	

Grit/ Grain: 40, 60, 80, 100, 120, 150, 180, 220, 280, 320, 400

Multi-Flex detachable Brushes

Versatility
Polyvalence

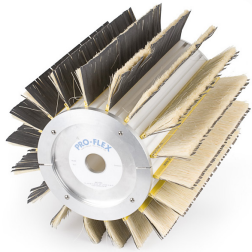

The **MULTI-FLEX** sanding system with detachable sanding brushes offers an extreme flexibility.

MULTI-FLEX is a quality product with proven efficiency for all types of flexible sanding, including profile and edge sanding.

The **MULTI-FLEX** brushes can also be used on surfaces where you need to eliminate unevenness, rotation grooves, loose fibre and sanding marks.

The **MULTI-FLEX** system also includes nylon brushes and hoghair for surface polishing.

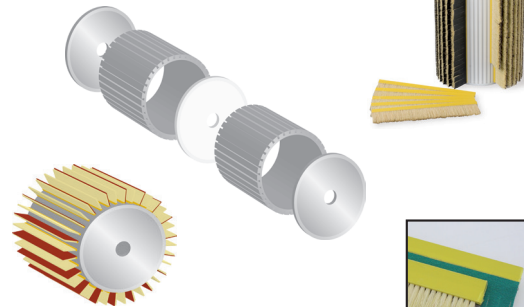
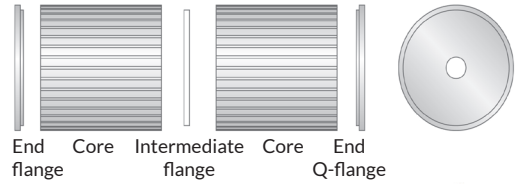

The **MULTI-FLEX** can be used with other sanding brush systems available on the market.

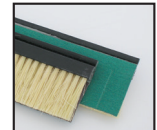

Brosses détachables Multi-Flex

Easy to built
Facile à monter



Le système **MULTI-FLEX** avec ses brosses à poncer détachables vous assure une plus grande flexibilité.

MULTI-FLEX est un produit de qualité éprouvé particulièrement adapté pour le ponçage des profilés, des moulures et des bords.

Les brosses **MULTI-FLEX** peuvent également servir à travailler les surfaces en vue d'éliminer les rugosités, les traces de rotations, les fibres relevées et les traces de ponçage.

Le système **MULTI-FLEX** comprend également des brosses en nylon ou en soie de porc pour le polissage.

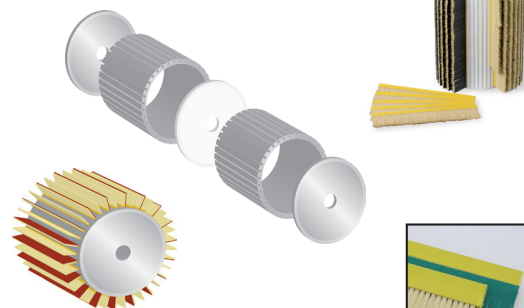
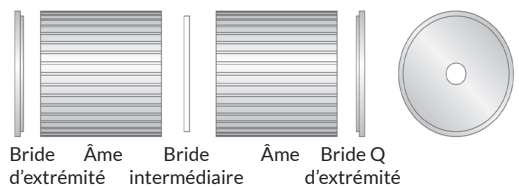

Les brosses **MULTI-FLEX** peuvent être utilisées avec les autres systèmes disponibles sur le marché

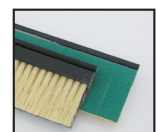

Choice of
Abrasives

Choix d'abrasifs

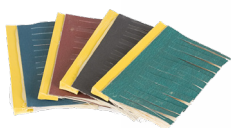

**1. SELECT BRUSH MODEL AND HEIGHT (H) IN MM /
1. CHOISISSEZ LE MODÈLE ET LA HAUTEUR (H) DE LA BROSE EN MM**

**A. Single brush with cloth
/ Brosse simple avec toile**

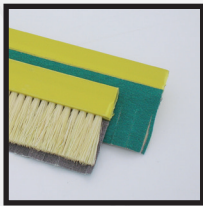

height (mm) /
hauteur (mm)

C. Single brush / Brosse simple



height (mm) /
hauteur (mm)

**B. Twin brush with cloth
/ Brosse double avec toile**

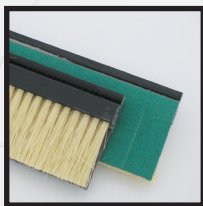

height (mm) /
hauteur (mm)

**D. Twin brush
/ Brosse double**



height (mm) /
hauteur (mm)

Model Modèle	Height (mm) Hauteur
-----------------	------------------------

**A. SINGLE BRUSH WITH CLOTH
BROSSE SIMPLE AVEC TOILE**

F30	30
F40	40
F45	45
F55	55
F70	70
F85	85

**B. TWIN BRUSH WITH CLOTH
BROSSE DOUBLE AVEC TOILE**

F30T	30
F40T	40
F55T	55
F70T	70

**C. SINGLE BRUSH
BROSSE SIMPLE**

F30S	30
F40S	40

**D. TWIN BRUSH
BROSSE DOUBLE**

F30TS	30
F40TS	40

2. DON'T FORGET TO SELECT:

- GRIT TYPE : ALUMINUM (AO) OR SILICONE CARBIDE (SC)
- GRIT SIZE : P060 À P500
- SLIT WIDTH : 3, 4, 5, 7, 14, 20 mm

2. N'OUBLIEZ PAS DE CHOISIR PARMIS :

- LE TYPE DE GRAIN : CORINDON (AO) OU CARBURE DE SILICIUM (SC)
- GROSSEUR DU GRAIN : P060 À P500
- LARGEUR DES FENTES : 3, 4, 5, 7, 14, 20 mm

PLEASE, COMMUNICATE WITH OUR CUSTOMER SERVICE TO GET A QUOTATION FOR CORE.

VEUILLEZ COMMUNIQUER AVEC NOTRE SERVICE À LA CLIENTÈLE POUR OBTENIR LE PRIX DES COEURS (ROUES)

POLISHING SYSTEM SYSTÈME DE POLISSAGE



Compound polissage

Pâte à

Cleaning solution lution dégraissante

So-

3.01 Fine Cut Compound 3.01 pâte à coupe fine			
	Volume	Part Number Num produit	Qty / case Qté / carton
	16 oz. (500 ml)	P03010500	10
	32 oz. (1000 ml)	P03011000	8
2.02 Medium Cut Compound 2.02 Pâte à coupe moyenne			
	Volume	Part Number Num produit	Qty / case Qté / carton
	16 oz. (500 ml)	P02020500	10
32 oz. (1000 ml)	P02021000	8	
1.09 Heavy Cut Compound 1.09 Pâte à forte coupe			
	Volume	Part Number Num produit	Qty / case Qté / carton
	16 oz. (500 ml)	P01090500	10
32 oz. (1000 ml)	P01091000	8	

ON-Finish - Spray Bottle ON-Finish - bouteille à vaporiser			
	Volume	Part Number Num produit	Qty / case Qté / carton
	16 oz. (500 ml)	P09200500	-

Premium WAX de première qualité

Cire

ON SYSTEM ON PREMIUM WAX EXCELLENCE POLISH-PAVEMENT INDUSTRY FINISH			
	Volume	Part Number Num produit	Qty / case Qté / carton
	200 ml		1

Polishing Pads Tampons de polissage

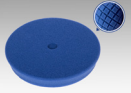
BLUE BLEU			
	Polishing Pad (spider) Tampons de polissage cannelés		
	Size Dimension	Part Number Num produit	Sleeve Paquet
	3-1/2" x 1" (90 x 25 mm)	P60250090	2
	6-5/8" x 1-1/8" (170 x 30 mm)	P60300170	1
7-5/8" x 1-1/8" (195 x 30 mm)	P60300195	1	

BURGUNDY BORDEAUX			
	Polishing Pad (spider) Tampons de polissage cannelés		
	Size Dimension	Part Number Num produit	Sleeve Paquet
	3-1/2" x 1" (90 x 25 mm)	P70250090	2
	6-5/8" x 1-1/8" (170 x 30 mm)	P70300170	1
7-5/8" x 1-1/8" (195 x 30 mm)	P70300195	1	

HONEY MIEL			
	Polishing Pad (spider) Tampons de polissage cannelés		
	Size Dimension	Part Number Num produit	Sleeve Paquet
	3-1/2" x 1" (90 x 25 mm)	P80250090	2
	6-5/8" x 1-1/8" (170 x 30 mm)	P80300170	1
7-5/8" x 1-1/8" (195 x 30 mm)	P80300195	1	

BLACK NOIR			
	Polishing Pad (spider) Tampons de polissage cannelés		
	Size Dimension	Part Number Num produit	Sleeve Paquet
	3-1/2" x 1" (90 x 25 mm)	P90250090	2
	6-5/8" x 1-1/8" (170 x 30 mm)	P90300170	1
7-5/8" x 1-1/8" (195 x 30 mm)	P90300195	1	

siafast Discs

Disques siafast

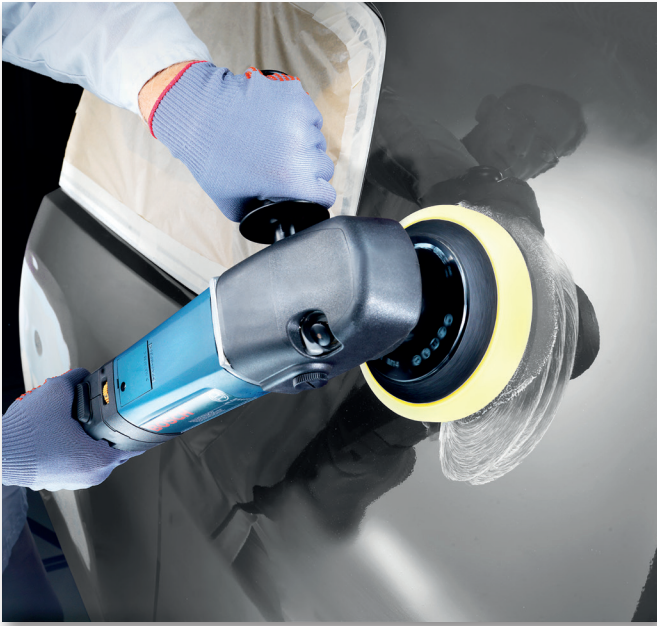

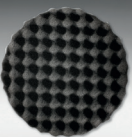

Lamb Skin Discs Disques en peau de mouton				
	3-3/8" (85 mm)		20	5
	5-3/8" (135 mm)		20	2
Yellow Discs Disques en mousse jaune				
	3-3/8" (85 mm)		20	5
	5-5/8" (145 mm)		20	2
Brown Discs Disques brun				
	3-3/8" (85 mm)		20	5
	5-5/8" (145 mm)		20	2
Yellow Discs with Nubbed Disques jaunes bosselés				
	8" (203 mm)		8	2

Black Discs Disques en mousse noir				
	Diameter Diamètre	Part Number No produit	Qty / case Qté / caisse	Qty / sleeve Qté / paquet
	3-3/8" (85 mm)	0020.6675	20	5
	5-5/8" (145 mm)	0020.6676	20	2
Black Discs with Nubbed Disques noir bosselés				
	8" (203 mm)	0020.7383	8	2

White Applicator (puck) - Rondelle blanche				
	Diameter Diamètre	Part Number No produit	Qty / case Qté / caisse	Qty / sleeve Qté / paquet
	5-1/8" (130 mm)	0020.6668	12	2

4" (100 mm)	Lamb Skin Peau mouton	
	Application	Part Number Numéro de produit
		048L.9144

Soft Foam Mousse souple	
	

6-1/2" (165 mm)	Wool Laine	
	Application	Part Number Numéro de produit
		043L.6124

7-1/2" (190 mm)	Soft Foam Mousse souple	
	Application	Part Number Numéro de produit
		047L.8367

siafast Discs

Disques siafast

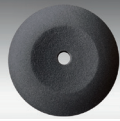
Extra Soft Foam Mousse extra souple	
	

8" (205 mm) Lamb Skin Peau mouton					
	<table border="1"> <tr> <th>Application</th> <th>Part Number Numéro de produit</th> </tr> <tr> <td>Compound</td> <td>044L.4263</td> </tr> </table>	Application	Part Number Numéro de produit	Compound	044L.4263
Application	Part Number Numéro de produit				
Compound	044L.4263				

8" (205 mm) Lamb Skin Peau mouton					
	<table border="1"> <tr> <th>Application</th> <th>Part Number Numéro de produit</th> </tr> <tr> <td>Polishing Polissage</td> <td>046L.1834</td> </tr> </table>	Application	Part Number Numéro de produit	Polishing Polissage	046L.1834
Application	Part Number Numéro de produit				
Polishing Polissage	046L.1834				

Lamb Skin Peau mouton					
	<table border="1"> <tr> <th>Application</th> <th>Part Number Numéro de produit</th> </tr> <tr> <td>Finishing Finition</td> <td></td> </tr> </table>	Application	Part Number Numéro de produit	Finishing Finition	
Application	Part Number Numéro de produit				
Finishing Finition					

Pads siafast Polishing Discs

Plateaux pour disques de polissage siafast

siafast Pad with shaft Plateau siafast avec tige						
	1-1/4" (32 mm)	5/16"	Soft Souple		10	1

siafast Pad with shaft Plateau siafast avec tige						
	3" (77 mm)	5/16"	Soft Souple		10	1

! Maximum 10 000 RPM

siafast Pad Plateau siafast							
	5" (125 mm)	5/8" - 11	Soft Souple		3 000	10	1
	6" (150 mm)	5/8" - 11	Medium Moyen		5 500	10	1

siafast Pad Plateau siafast							
	Diameter Diamètre	Fastener Attache	Hard. Dureté	Part Number No produit	Max. RPM	Case Caisse	Sleeve Paquet
	3-1/2" (90 mm)	5/8" - 11	Soft Souple	042L.1821	2 000	10	1
	5" (125 mm)	5/8" - 11	Soft Souple	998L.0125	3 000	10	1
	8" (200 mm)	5/8" - 11	Soft Souple	041L.6629	3 000	10	1

siafast Pad Plateau siafast							
	Diameter Diamètre	Fastener Attache	Hard. Dureté	Part Number No produit	Max. RPM	Case Caisse	Sleeve Paquet
	3" (74 mm)	5/8" - 11	Soft Souple	P58110074	-	-	2
	6" (148 mm)	5/8" - 11	Soft Souple	P58110148	-	-	1
	7" (178 mm)	5/8" - 11	Soft Souple	P58110178	-	-	1

Intermediate Disc (6 holes) Disque intermédiaire (6 trous)							
	3" (77 mm)	1 mm				10	1
		5 mm				10	1

Micro Fiber Cloths Chiffons en micro fibre

BLUE Microfiber Cloth Tissus en microfibre de couleur bleue				
	Size Dimension	Part Number No produit	Qty / case Qté / caisse	Qty / sleeve Qté / paquet
	15-3/4" x 15-3/4" (400 x 400 mm) recto / verso	D10210000	-	25

GREEN Microfiber Cloth Tissus en microfibre de couleur verte				
	Size Dimension	Part Number No produit	Qty / case Qté / caisse	Qty / sleeve Qté / paquet
	15" x 15" (380 x 380 mm) recto / verso	D10220000	-	25

Yellow Cloth (for siachrome CUT) Linge jaune (pour le siachrome CUT)				
	Size Dimension	Part Number No produit	Qty / case Qté / caisse	Qty / sleeve Qté / paquet
	15" x 15" (380 x 380 mm)	0020.3185	9	3

Black Cloth (Premium) Linge noir (Premium)				
	Size Dimension	Part Number No produit	Qty / case Qté / caisse	Qty / sleeve Qté / paquet
	15-3/4" x 15-3/4" (400 x 400 mm)	0020.6670	15	1



Water Proof Matting Paste Pâtes de matage hydrofuge

siamat				
	Size Format	Part Number No produit	Qty / case Qté / caisse	Qty / sleeve Qté / paquet
	16 oz (500 ml)	0020.4174	10	1





SPECIALITIES

(SPIRAL BANDS & FLAPWHEELS, CARTRIDGES ROLLS, CROSS PADS)

SPÉCIALITÉS

(MANCHONS & ROUES À LANGUETTES, CARTOUCHES, TAMPONS EN CROIX)



Resin-Bond Spiral Bands

Manchons en spirale

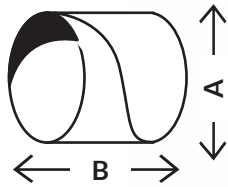

A
INSIDE DIAMETER
DIAMÈTRE INTÉRIEUR

B
LENGTH
LONGUEUR

LENGTH LONGUEUR	MINIMUM ORDER COMMANDE MINIMUM
1/2 - 2"	50
3 - 4"	25
6 - 9"	10

2920 siawood	Aluminum Oxide (x-cloth) Corindon (toile-x)
	Available upon request Disponible sur demande

2820 siamet	Zirconia (x-cloth) Zirconium (toile-x)
	Available upon request Disponible sur demande

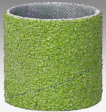
2511 siabite	Ceramic (x-cloth) Céramique (toile-x)
	Available upon request Disponible sur demande

	SCM
	Available upon request Disponible sur demande

Mandrels

Mandrins

Quick-Lock	Rubber drums Tambours en caoutchouc							
	Dia.	Shank Tige	Length - Longueur					
			1/2"	3/4"	1"	1 1/2"	2"	3"
	3/8"	1/4"	D-608-2	D-612-2	D-616-2	D-624-3	D-632-2	D-648-3
	1/2"	1/4"	QL-808	QL-812	QL-816	QL-824	QL-832	QL-848
	3/4"	1/4"	QL-1208	QL-1212	QL-1216	QL-1224	QL-1232	QL-1248
	1"	1/4"	QL-1608	QL-1612	QL-1616	QL-1624	QL-1632	QL-1648
	1 1/2"	1/4"	QL-2408	QL-2412	QL-2416	QL-2424	QL-2432	QL-2448
	2"	1/4"	QL-3208	QL-3212	QL-3216	QL-3224	QL-3232	QL-3248
	2 1/2"	1/4"	QL-4008	QL-4012	QL-4016	QL-4024	QL-4032	QL-4048
	3"	1/4"	QL-4808	QL-4812	QL-4816	QL-4824	QL-4832	QL-4848

Slotted Fentes	Rubber drums Tambours en caoutchouc					
	Dia.	Shank Tige	Length - Longueur			
			1"	1 1/2"	2"	3"
	3/8"	1/4"	C138E11	C138E115	C138E12	C138E13
	1/2"	1/4"	C138E151	C138E1515	C138E152	C138E153
	3/4"	1/4"	C138E21	C138E215	C138E22	

Maximum RPM - RPM maximum							
Dia.	Shank Tige	Length - Longueur					
		1/2"	3/4"	1"	1 1/2"	2"	3"
3/8"	1/4"	30	25	20	12	10	6 000
		000	000	000	000	000	
1/2"	1/4"	30	25	20	12	10	6 000
		000	000	000	000	000	
3/4"	1/4"	27	24	19	10	9 000	6 000
		000	000	000	000		
1"	1/4"	20	19	18	10	8 000	6 000
		000	000	000	000		
1 1/2"	1/4"	16	15	14	10	7 000	6 000
		000	000	000	000		
2"	1/4"	13	12	11	11	8 000	6 000
		000	000	000	8 000	6 000	
2 1/2"	1/4"	7 000	6 000	6 000	6 000	4 000	3 000
3"	1/4"	7 000	6 000	6 000	6 000	4 000	3 000

Mounted Flap Wheels with shank 1/4" (6 mm) sur tige Roues à languettes 1/4" (6 mm)

Aluminum Oxide (x-cloth) - Corindon (toile-x)						
	Diameter Diamètre	Shank Tige	Width Largeur	Grit Grain	P. Number No. produit	Qty / sleeve Qté / paquet
	3/8" (10 mm)	1/8" (3 mm)	3/8" (10 mm)	60 - 320	RL383818	10
	5/8" (16 mm)	1/4" (6 mm)	5/8" (16 mm)	60 - 320	RL585814	10
		1/4" (6 mm)	3/4" (19 mm)	60 - 320	RL583414	10
	3/4" (19 mm)	1/4" (6 mm)	3/16" (5 mm)	60 - 320	RL3431614	10
		1/4" (6 mm)	3/8" (10 mm)	60 - 320	RL343814	10
		1/4" (6 mm)	1/2" (13 mm)	60 - 320	RL34514	10
		1/4" (6 mm)	5/8" (16 mm)	60 - 320	RL345814	10
		1/4" (6 mm)	3/4" (19 mm)	60 - 320	RL343414	10

*Add grit size to part number. Specify shank type 1/8 or 1/4 Inch.
Ajouter le grain au numéro de la pièce. Spécifiez la tige - 1/8 ou 1/4 pouce*

Max RPM 35 000 Optimal RPM 20 000

Aluminum Oxide (x-cloth) - Corindon (toile-x)					
	Diameter Diamètre	Width Largeur	Grit Grain	P. Number No. produit	Qty / sleeve Qté / paquet
	1" (25 mm)	3/8" (10 mm)	60 - 320	RL13818	10
		1/2" (13 mm)	60 - 320	RL11218	10
		3/4" (19 mm)	60 - 320	RL13418	10
		1" (25 mm)	60 - 320	RL11118	10

*Add grit size to part number. Specify shank type 1/8 in. (3 mm)
Ajouter le grain au numéro de la pièce.
Spécifiez la tige - 1/8 pouce (3 mm)*

Max RPM 25 000 Optimal RPM 22 000

Diameter Diamètre	Most Effective Speed Vitesse la plus efficace (R.P.M.)	Maximum Speed Vitesse maximale (R.P.M.)
<1" (<25 mm)	20 000	35 000
1" (25 mm)	22 900	25 000
1-1/2" (38 mm)	17 100	25 000
2" (50 mm)	13 700	25 000
2-1/2" (64 mm)	11 400	20 000
3" (76 mm)	8 500	20 000

Aluminum Oxide (x-cloth) - Corindon (toile-x)						
	Diameter Diamètre	Width Largeur	Grit Grain	Part Number No de produit	Qty / sleeve Qté / paquet	
	1" (25 mm)	3/8" (10 mm)	320 - 40	RL13814	10	
		1/2" (13 mm)	320 - 40	RL1514	10	
		5/8" (16 mm)	320 - 40	RL15814	10	
		3/4" (19 mm)	320 - 40	RL13414	10	
		1" (25 mm)	320 - 40	RL1114	10	
		1 1/2" (38 mm)	3/8" (10 mm)	320 - 40	RL153814	10
			1/2" (13 mm)	320 - 40	RL15514	10
	5/8" (16 mm)		320 - 40	RL155814	10	
	3/4" (19 mm)		320 - 40	RL153414	10	
	1" (25 mm)		320 - 40	RL15114	10	
	2" (50 mm)	1 1/2" (38 mm)	320 - 40	RL151514	10	
		3/8" (10 mm)	320 - 40	RL23814	10	
		1/2" (13 mm)	320 - 40	RL2514	10	
		5/8" (16 mm)	320 - 40	RL25814	10	
		3/4" (19 mm)	320 - 40	RL23414	10	
		1" (25 mm)	320 - 40	RL2114	10	
		1 1/2" (38 mm)	320 - 40	RL21514	10	
	2 1/2" (64 mm)	2" (50 mm)	320 - 40	RL2214	10	
		1/2" (13 mm)	320 - 40	RL25514	10	
		5/8" (16 mm)	320 - 40	RL255814	10	
		3/4" (19 mm)	320 - 40	RL253414	10	
		1" (25 mm)	320 - 40	RL25114	10	
		1 1/2" (38 mm)	320 - 40	RL251514	10	
		2" (50 mm)	320 - 40	RL25214	10	
	3" (76 mm)	1/2" (13 mm)	320 - 40	RL3514	10	
		5/8" (16 mm)	320 - 40	RL35814	10	
		3/4" (19 mm)	320 - 40	RL33414	10	
		1" (25 mm)	320 - 40	RL3114	10	
		1 1/2" (38 mm)	320 - 40	RL31514	10	
		2" (50 mm)	320 - 40	RL3214	10	

*Add grit size to part number.
Ajouter le grain au numéro de la pièce.*

Mounted Flap Wheels Roues à languettes montées sur tige

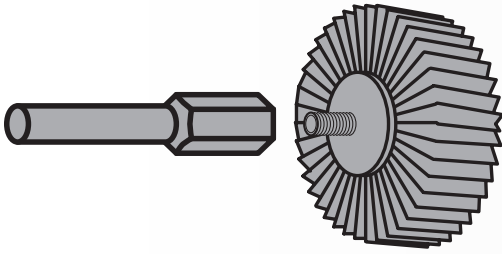

Mounted Flap Wheels with 1/4 - 20 threaded shank and their mandrel are also available upon request

Les roues à languettes montées sur tige filetée 1/4 - 20 et leur mandrin sont aussi disponibles sur demande

Non woven and Interleaf non woven mounted Flap wheels Roues à languettes non tissé ou combo avec une toile abrasive



Nonwoven and Interleaf non woven mounted Flap wheels are available upon request

Les roues à languettes confectionnées en matériel non tissé ou en combo avec une toile abrasive sont disponibles sur demande

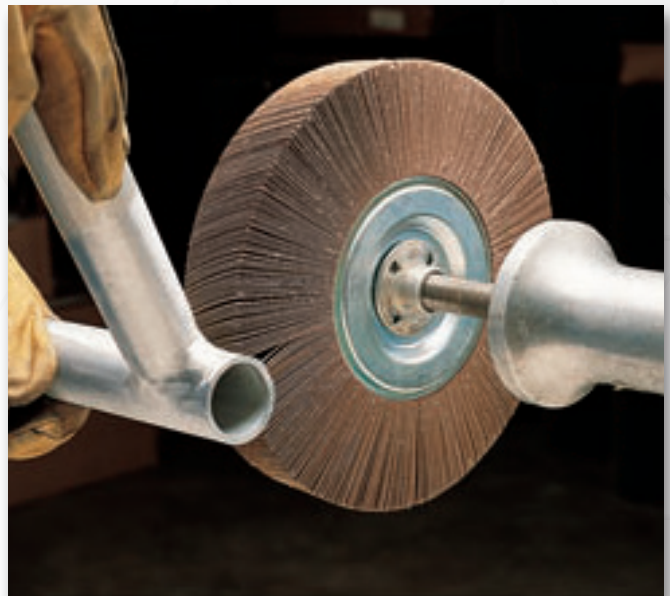

Cartridge Rolls Cartouches



**Straight Cartridge
Cartouche droite**

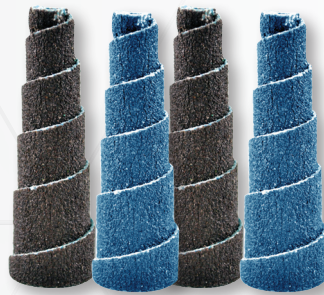

**Full Tapered Cartridge
Cartouche conique**

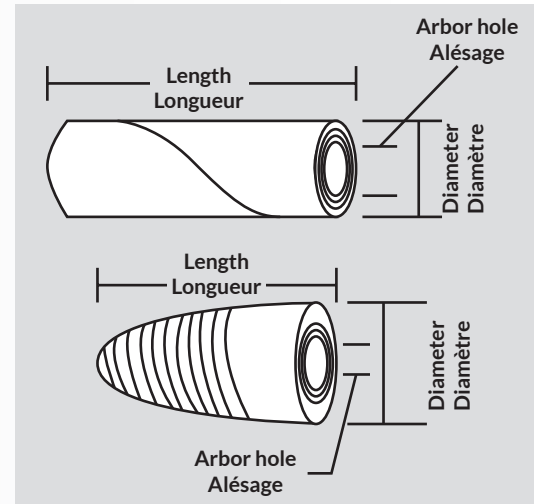

**Available upon request
Disponible sur demande**

To order
Pour commander

Diameter
Diamètre
Length
Longueur
Arbor Hole
Alésage
Grit
Grain

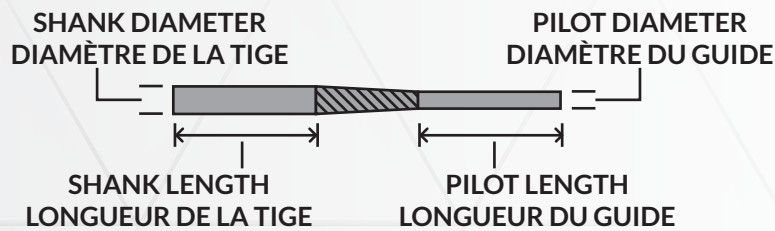

**Available upon request
Disponible sur demande**

To order
Pour commander

Pilot Diameter
Diamètre du Guide
Pilot Length
Longueur du Guide
Shank Diameter
Diamètre de la tige
Shank Length
Longueur de la tige
Grit
Grain

**RECOMMENDED PILOT LENGTH FOR MANDRELS
LONGUEUR DE GUIDE RECOMMANDÉ POUR MANDRIN**

ROLL LENGTH LONGUEUR DU ROULEAU	PILOT LENGTH LONGUEUR DU GUIDE
3/4" (19 mm)	1/2" (25 mm)
1" (25 mm)	3/4" (19 mm)
1 1/2" (38 mm)	1" (25 mm)
2" (50 mm)	1 1/2" (38 mm)

Cross Pads Tampons en croix

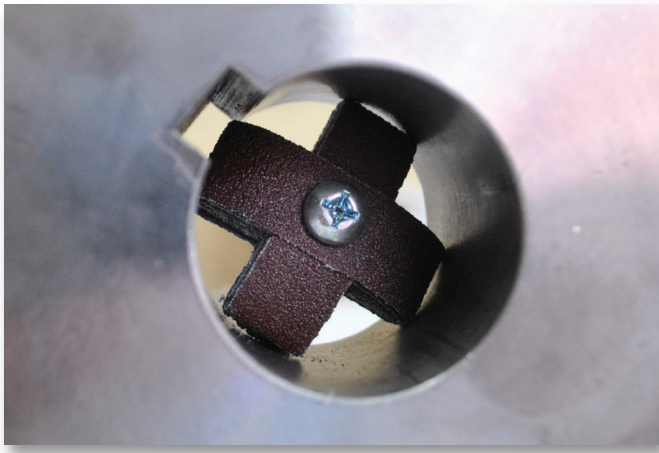
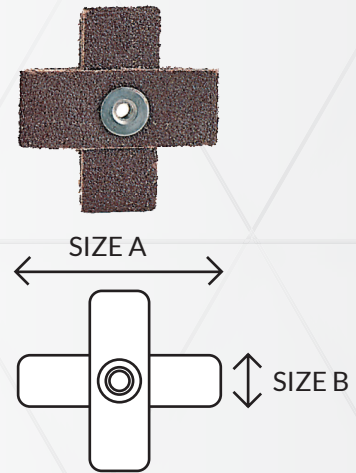

Available upon request
Disponible sur demande

To order
Pour commander

Size (A)
Dimension
Width (B)
Largeur
Number of Plys
Nombre d'épaisseur
Size Eyelet or Bolt
Dim. de l'oeillet / boulon
Grit
Grain

Mandrels for Cartridge Rolls Mandrins pour Cartouches

Mandrel Fitting for Bolts
Mandrins pour Boulons



Mandrel Fitting for Threaded Eyelets
Mandrins pour oeillets



Available upon request
Disponible sur demande

To order
Pour commander

Shaft
Tige
Length
Longueur
Attachment
Filet



ACCESSORIES ACCESSOIRES



9089 Siaklett Conversion System - Système de conversion siaklett

Strips Coupes

Size Dimension	Holes Number Nombre de trous	Part Number Numéro de produit
2-3/4" x 17-1/2" (70 x 445 mm)	No hole Sans trou	6096.7887.0000
	14 holes 14 trous	1014.3429.0000
3-1/8" X 11" (85 X 280 mm)	No hole Sans trou	5994.6657.0000
3-2/3" X 9" (95 x 230 mm)	No hole Sans trou	0596.3968.0000
4-1/2" X 1" (115 X 25 mm)	No hole Sans trou	4557.8729.0000

Strips Coupes

Size Dimension	Holes Number Nombre de trous	Part Number Numéro de produit
4-3/8" x 5-1/2" (110 x 140 mm)	No hole Sans trou	6274.3623.0000
4-1/2" X 11" (115 X 280 mm)	No hole Sans trou	7088.2671.0000
	10 holes 10 trous	7088.4966.0000
12" X 24" (305 X 610 mm)	No hole Sans trou	2844.4474.0000
24" X 24" (610 X 610 mm)	No hole Sans trou	6330.4059.0000

Discs - Disques

Diameter Diamètre	Holes Number Nombre de trous	Part Number Numéro de produit
4-1/2" (115 mm)	No hole Sans trou	7088.6933.0000
5" (125 mm)	No hole Sans trou	9142.8492.0000
	5 holes 5 trous	3204.7084.0000
	8 holes 8 trous	0678.1224.0000
6" (150 mm)	No hole Sans trou	9692.0437.0000
	7 holes 7 trous	0829.5083.0000
	15 holes 15 trous	4582.3519.0000

Discs - Disques

Diameter Diamètre	Holes Number Nombre de trous	Part Number Numéro de produit
7" (180 mm)	No hole Sans trou	0330.7046.0000
8" (200 mm)	No hole Sans trou	0801.0225.0000
9" (225 mm)	No hole Sans trou	1438.4338.0000
10" (250 mm)	No hole Sans trou	6581.2131.0000
12" (305 mm)	No hole Sans trou	3064.3952.0000
16" (410 mm)	No hole Sans trou	5349.3433.0000
20" (500 mm)	No hole Sans trou	5557.6942.0000
24" (610 mm)	No hole Sans trou	6330.4059.0000

Roll - Rouleau

Width Largeur	Length Longueur	Part Number Numéro de produit
4-1/2" (115 mm)	11 yds 10 m	1180.7962.0000

Roll - Rouleau

Width Largeur	Length Longueur	Product Number Numéro de produit
4-1/2" (115 mm)	27 yds 25 m	6559.0540.0000

Siaklett Conversion System for Profils Système de conversion siaklett pour profilés

For profil sanding (extensible) Pour ponçage des profils (élastique)				
Width Largeur	Length Longueur	P. Number N. produit	Sleeve Paquet	
	27-1/2" (700 mm)	19-1/2" (500 mm)	5797.3499.0000	2
	27-1/2" (700 mm)	39-3/4" (1000 mm)	6640.4283.0000	2

Various Items - Divers items

Microfiber Micro fibre		Yellow Jaune	
Size Dimension		Part Number Numéro de produit	
	15" x 15" (380 x 380 mm)	0020.3185	
	Qty / case Qté / caisse	9	
	Qty / sleeve Qty / paquet	3	

Microfiber Micro fibre		Black Noir (PREMIUM)	
Size Dimension		Part Number Numéro de produit	
	15-3/4" x 15-3/4" (400 x 400 mm)	0020.6670	
	Qty / case Qté / caisse	15	
	Qty / sleeve Qty / paquet	1	

Cheese Cloth Coton fromage		Tack Cloth Chiffon de finition imprégné			
Width Largeur	Length Longueur	P. Number N. produit	Case Caisse	Sleeve Paquet	
	12-1/2" (320 mm)	15-3/4" (400 mm)	0020.0016	240	10
	25-1/2" (650 mm)	29-1/2" (750 mm)	0020.0088	300	50

Suction Hose Tuyau d'aspiration		Part Number Numéro de produit
	Length Longueur	0020.3925
	14 ft (4 500 mm)	
	Diameter Diamètre	1" (25 mm)

Abrasive Belt Cleaner Nettoyeur de bandes abrasives		P. Number N. produit	Case Caisse	Sleeve Paquet
	1-5/8" x 1-5/8" x 8-1/4"	0020.2302	6	1
	(40 x 40 x 210 mm)			

Sanding Guide Powder Guide de ponçage		Case Caisse	Sleeve Paquet
	P. Number N. produit	6	1
	0020.2302		

Paint Strainers Filtres à peinture		Part Number Numéro de produit
	Fine / nylon	004A.4673
	Qty / case Qté / caisse	1000
	Qty / sleeve Qty / paquet	100

Powder Refill Cartouche de poudre		Case Caisse	Sleeve Paquet
	P. Number N. produit	36	6
	0020.2302		

Strip Eraser (with 1/4" shaft) Gomme à effacer (tige 6 mm inclu)		P. Number N. produit	Case Caisse	Sleeve Paquet
	3-1/2" (88 mm)	0020.0016	20	1
	9/16" (15 mm)			

Dust Mask Masque de protection		Case Caisse	Sleeve Paquet
	P. Number N. produit	0020.0016	1
	0020.0016		

siaglove Antivibration Gloves Gants anti vibration siaglove		Part Number Numéro de produit
	Size Dimension	905B.0081
	Small Petit	
	Medium Moyen	
	Large Grand	
Extra-Large Très grand	905B.0061	

Sanding Technology

Backing Pad Type		Grit	Type of work	
Soft 5,0 orbit	Hard 5,0-10,0 or-bit	40	- Mechanical lacquer removal	
		60		
		80	- Sanding out, flatting of body filler	
		100		
		120		
	150	- Sanding out, flatting of body filler		
	Extra soft 2,5-5,0 orbit		180	- Keying of factory primers
			220	
			240	
			280	
320				
360		- Flattening of primer filler		
Intermediate pad			400	- Fine sanding of primer filler (two-component lacquers)
			500	- Fine sanding of primer filler (two-layer lacquers)
			600	- Refining and de-nibbling surfaces using siavlies ultra fine
			800	- Keying of old lacquer and subsequent clear coating
	1000		- Scuffing / keying for blending	
	1200	- Retouching of new lacquer		
	1500	(orange-peel effect, dust inclusions)		

Important : do not skip more than two grit sizes ...



Type de plateau support		Grain	Genre de travail			
Souple course 5,0	Dur Course 5,0- 10,0	Important : sauter 2 grains au maximum ...	40	- Dévernissage mécanique		
			60			
			80	- Surface, ponçage de mastics		
			100			
			120	- Surface, ponçage de mastics		
			150			
			180	- Ponçage de couches de fond provenant de l'usine		
			220			- Réparations finitions
			240			- Finition des mastics (avant l'application d'enduits)
			Interface souple	Extra-souple course 2,5-5,0	Important : sauter 2 grains au maximum ...	280
320						
360	- Finition d'apprêts (laques à deux composantes)					
400						
500	- Finition d'apprêts (laques à deux couches)					
600	- Finition et enlèvement de poussières					
800	- Ponçage de vieux vernis avant nouvelle application					
1000	- Matage / égalisation avant retouches de vernis					
			1200	- Retouches de laques (peau d'orange, inclusion de poussières)		
			1500			

Ask us for Special Training on Abrasives

Demandez une formation spéciale sur les abrasifs



GRIT USE

GUIDE D'UTILISATION DES GRAINS

GRIT / GRAIN	APPLICATION APPLICATION
PRODUCTION / PRODUCTION	
16	<ul style="list-style-type: none"> Major removal of material and levelling a surface Enlèvement important du matériel et renouvellement de la surface
24	
36	
40	
PRODUCTION / PRODUCTION	
50	<ul style="list-style-type: none"> Fast stock removal Ajustement de l'épaisseur du matériel
60	
PRODUCTION / PRODUCTION	
80	<ul style="list-style-type: none"> Medium removal of material and decreases previous sanding lines Enlèvement moyen du matériel et diminution des lignes de sablage
100	
PRODUCTION / PRODUCTION	
120	<ul style="list-style-type: none"> First stage of sanding before finishing on the raw material Première étape de sablage avant la finition sur la matière première
150	
180	
FINISH / FINITION	
220	<ul style="list-style-type: none"> First sanding step on primers Cut the surface to make it straight Cut orange peel Première étape de sablage sur les apprêts Couper la surface pour la rendre droite Couper la pelure d'orange
240	
280	
320	
FINISH / FINITION	
400	<ul style="list-style-type: none"> Sanding between layers of Primers, dyes, paints Sablage entre les couches d'apprêts, teintures, peintures
400	
FINISH / FINITION	
500	<ul style="list-style-type: none"> Use as needed to decrease sanding lines left by previous grits Utiliser au besoin pour diminuer les lignes de sablage laissées par les grains précédents
600	
FINISH / FINITION	
800	<ul style="list-style-type: none"> Cut for preparation of polishing For glossy finishes Couper pour la préparation du polissage Pour les finis lustrés
1000	
1200	
1500	<ul style="list-style-type: none"> Before using polishing pastes Avant utilisation des pâtes à polir

GOOD USE OF GRITS BONNE UTILISATION DES GRAINS



GRIT / GRAIN
80

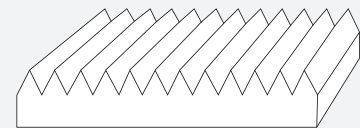

GRIT / GRAIN
120

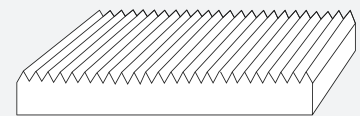

GRIT / GRAIN
180

WRONG USE OF GRITS MAUVAISE UTILISATION DES GRAINS

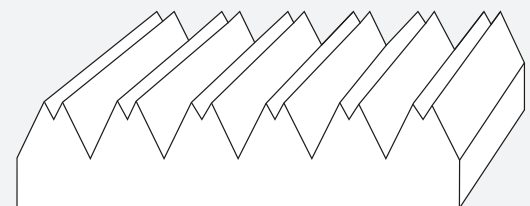
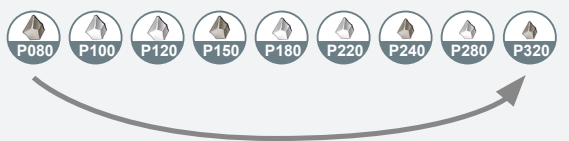

ORDER FORM

BON DE COMMANDE

To / À: Customer Service
Service à la clientèle



FAX No. / Lévís (418) 836-0537
No télécopieur Newmarket (905) 898-2405

From / De: _____

Company Name /
Nom de la compagnie _____

FAX No. /
No télécopieur _____

Date: ____/____/____

Expected Delivery Date
Date de livraison prévue: ____/____/____

Ship via
Expédié par _____

Order Number
Numéro de commande: [Redacted]

Quantity Quantité	Part Number Numéro de produit	Grit Grain	Description / Comments Description / Commentaires	Unit Price (\$) Prix unitaire (\$)

IF NEW CUSTOMER /
SI NOUVEAU CLIENT

ADDRESS / ADRESSE

Signature

Name / Nom



Votre source de solutions
Your Solution Partner



JJS Canada Inc.

ONTARIO/WEST CANADA

📍 1251 Gorham Street, Unit 11

Newmarket (ON) | L3Y 8Y6

📞 +1 800 337-1325

📞 +1 905 898-0116

✉️ orderdesk@jjscanada.ca

🌐 jjscanada.ca

JJS Canada Inc.

QUEBEC

📍 900 Chemin Olivier,

Levis(QC) | G7A 2N1

📞 +1 800 463-1574

📞 +1 418 836-0557

✉️ commandes@jjscanada.ca

🌐 jjscanada.ca